

PROJECT: 2024 US OPEN PLANTINGS - MOORE & LEE CO.

STATE OF NORTH CAROLINA  
DIVISION OF HIGHWAYS

# MOORE & LEE COUNTY

STATE	STATE PROJECT REFERENCE NO.	SHEET NO.	TOTAL SHEETS
N.C.		L1	17

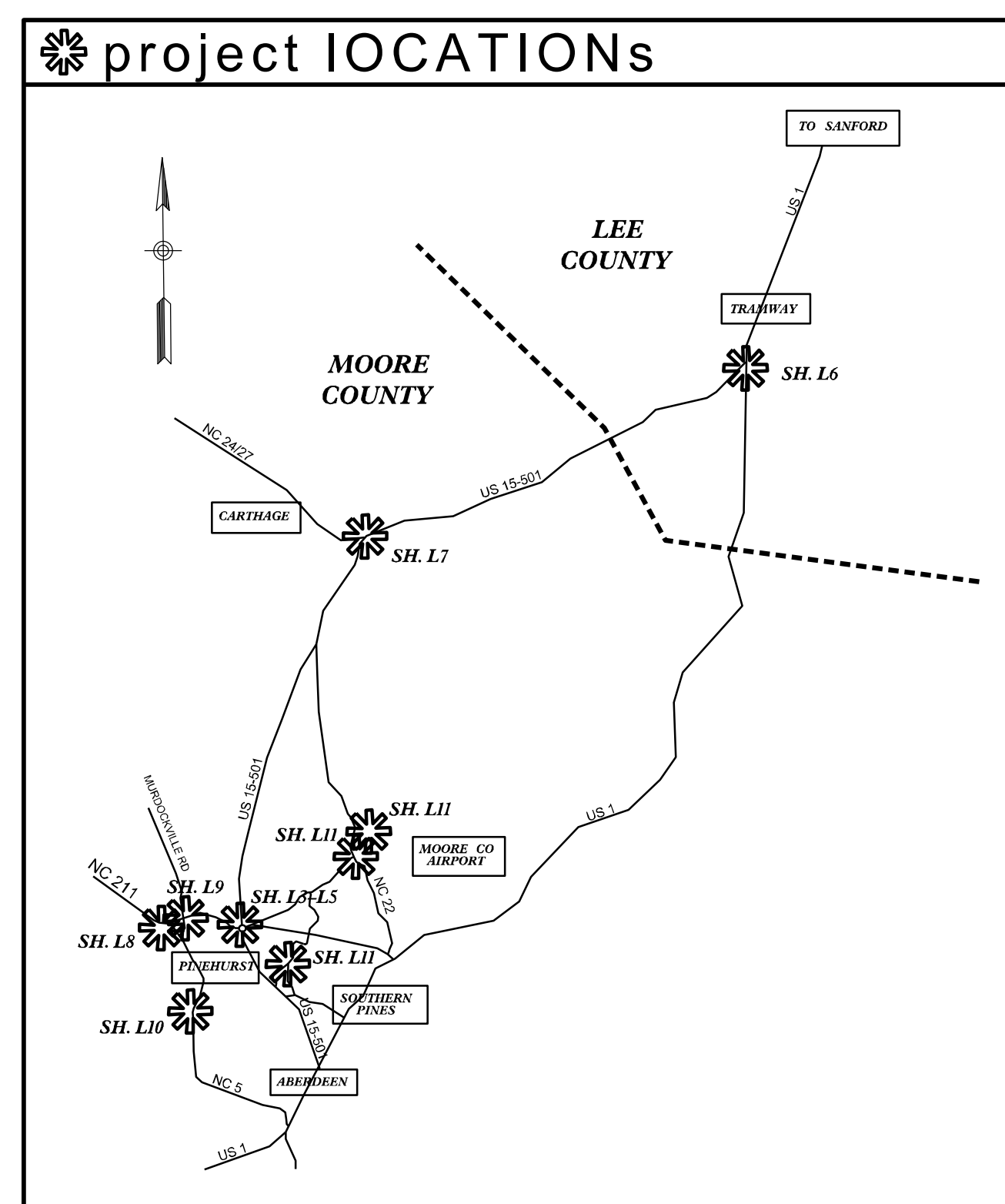
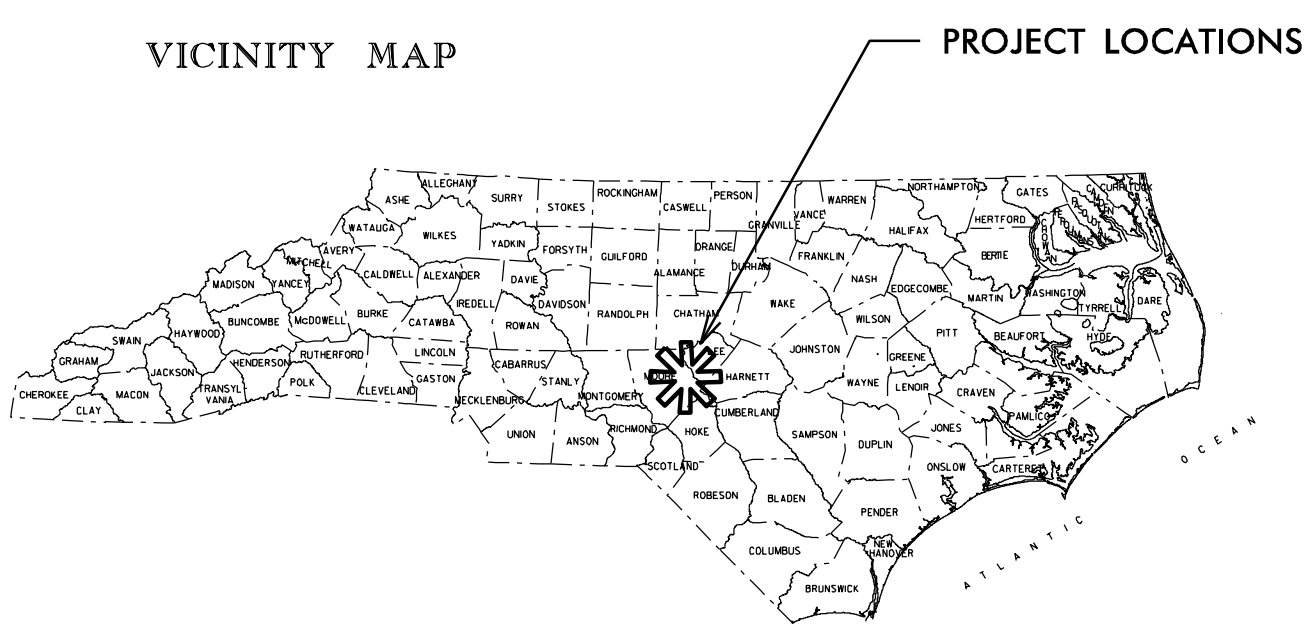

LOCATION: Multiple Locations including the PINEHURST TRAFFIC CIRCLE  
TYPE OF WORK: Bed Preparation, ANNUAL PLANTINGS, and establishment care

SUMMARY OF QUANTITIES

Annual Quantities						
Quantity	Unit	Key	Plant Name	Common name	Spacing	
396	EA	ABR	Alternanthera 'Brazilian Red Hots'	Brazilian Red Hot Alternanthera	12" O.C.	
3960	EA	BOR	Begonia 'Super Olympic Red'	Super Olympic Red Begonia	12" O.C.	
3600	EA	BOW	Begonia 'Super Olympic White'	Super Olympic White Begonia	12" O.C.	
180	EA	DGM	Duranta 'Gold Mound'	Gold Mound Duranta	18" O.C.	
350	EA	IB	Ipomoea 'Blackie'	Blackie Sweet Potato Vine	18" O.C.	
250	EA	ITL	Ipomoea 'Terrace Lime'	Terrace Lime Sweet Potato Vine	18" O.C.	
1890	EA	PB	Petunia 'Easy Wave Blue'	Easy Wave Blue Petunia	12" O.C.	
1980	EA	PR	Petunia 'Easy Wave Red'	Easy Wave Red Petunia	12" O.C.	
2790	EA	PP	Petunia 'Easy Wave Pink'	Easy Wave Pink Petunia	12" O.C.	
5076	EA	PW	Petunia 'Easy Wave White'	Easy Wave White Petunia	12" O.C.	
360	EA	SVB	Salvia farinacea 'Victoria Blue'	Victoria Blue Salvia	16" O.C.	
Perennial Quantities						
1850	Each	HB	Hemerocallis 'Buttered Popcorn'	Buttered Popcorn Daylily	#1 Cont, 2' O.C.	
260	Each	RF	Rubeckia fulgida	Blacked Eyed Susan	#1 Cont, 2' O.C.	
Descriptions						
200	CY		Topsoil			
175	CY		Pine Bark Fines			
50	CY		Mulch for Perennial Beds			
1	LS		Traffic Control			
2272	SY		Plant Bed Preparation			
16	Each		Plant Bed Establishment			
20,232	Each		Installation of Annuals, 18 per Flat			
600	Each		Installation of Annuals, 10 per Flat			
2110	Each		Installation of Perennials, #1 Container			
1	LS		Irrigation			

Notes:  
Contractor and Engineer will coordinate delivery of the annuals prior to installation. Proposed time schedule and desired delivery locations will be agreed upon prior to initiation of work.

annuals delivered to site will include one extra flat of each annual Variety (to be used as replacement plant material as determined or directed by NCDOT engineer).

CONVENTIONAL SYMBOLS

County Line	-----
City or Town Line	-----
Exist. Right of Way Line Marker	-----▲-----
Prop. Right of Way Line Marker (By Others)	-----▲-----
Prop Right of Way Line Marker (By Contract)	-----▲-----
Exist. Control of Access Line	-----○-----
Prop. Control of Access Line	-----○-----
Property Line	-----
Easement Line	-----
Slope Stake Line	-----
Exist. Fence	-----
Prop. Woven Wire Fence	-----
Prop. Chain Link Fence	-----
Exist. Road	=====
Prop. Road	=====
Guardrail	-----
Survey Line	-----
Denotes Line Equality	-----
Bridge	-----
Culvert	-----
Railroad	-----
Woods	-----
Exist. Telephone Pole	-----
Prop. Telephone Pole	-----
Tower Pole and Line	-----
Exist. Power Pole	-----
Prop. Power Pole	-----
Sanitary Sewer Line	-----
Water Line	-----
Gas Line	-----
Picnic Shelter	-----
Regeneration	-----
Reforestation	-----

REVISIONS

DATE	DESCRIPTION

2004 American Standard for Nursery Stock  
2024 NCDOT STANDARD SPECIFICATIONS  
PREPARED IN THE OFFICE OF:  
NCDOT- ROADSIDE ENVIRONMENTAL UNIT  
LANDSCAPE DESIGN & DEVELOPMENT SECTION  
1557 MAIL SERVICE CENTER  
RALEIGH NC 27699 919-707-2935

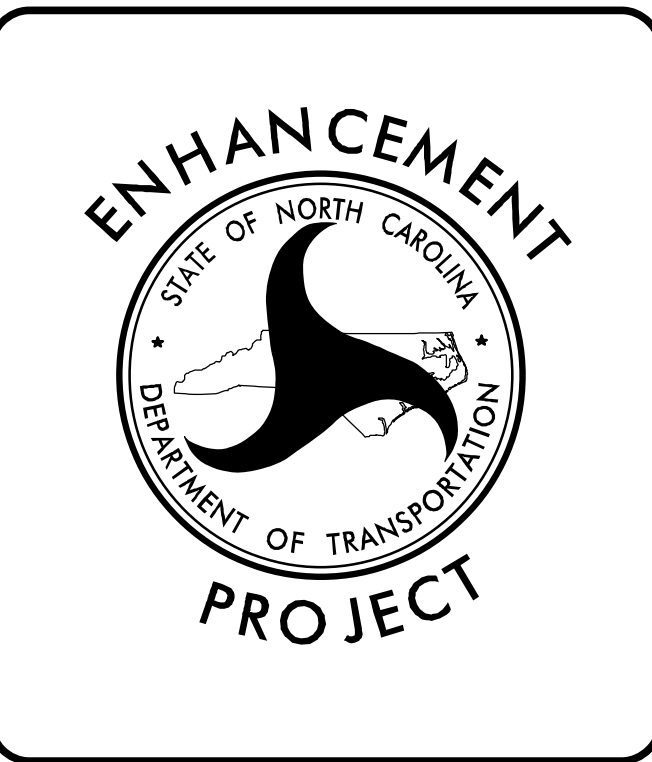
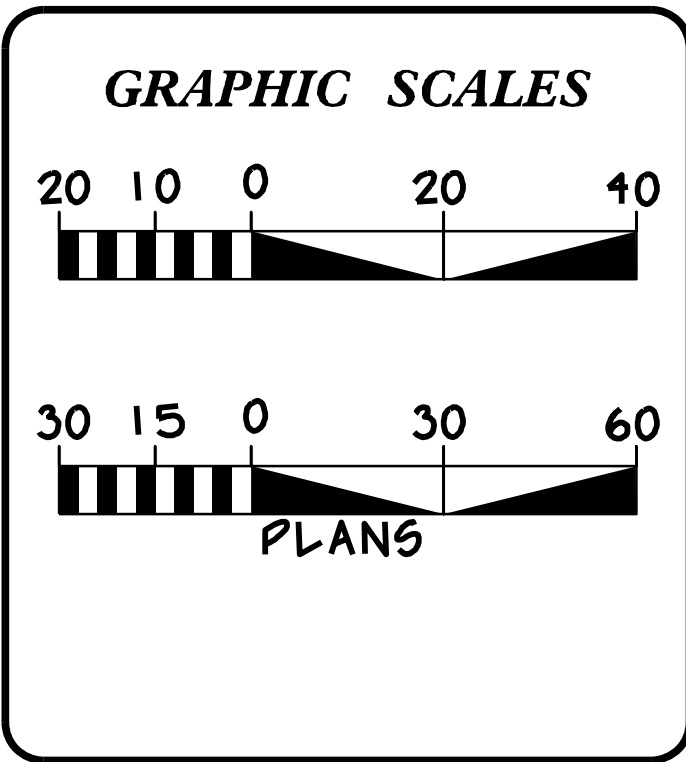

INDEX OF SHEETS :

TITLE, DESCRIPTION, & SUMMARY OF QUANTITIES	L1
LANDSCAPE DETAILS	L2
LANDSCAPE PLANS	L3-L11
IRRIGATION PLANS	I1-I6

Prepared In the Office of:  
**ROADSIDE ENVIRONMENTAL UNIT  
DEPARTMENT OF TRANSPORTATION  
DIVISION OF HIGHWAYS**  
RALEIGH, N.C.

**2024 STANDARD SPECIFICATIONS**

Drawn By: Design Section NOV-2024

NOTES:

CONTRACTOR SHALL CONSULT THE DIVISIONS SPECIAL PROVISIONS FOR PROCEDURES FOR PREPARING ANNUAL BEDS, INSTALLATION, FUMIGATION AND PLANT BED AMENDMENTS. NO PROGRESS OF ANNUAL DEVELOPMENT OR INSTALLATION SHALL TAKE PLACE UNTIL THESE SPECIAL PROVISIONS ARE REVIEWED AND AGREED UPON.

ALL ANNUALS SHALL BE SPACED ON 12" AND/OR 18" CENTERS. ANNUALS SHALL BE SET AT A PROPER POSITION AS REGARDS TO DEPTH TO PLANT TO SOIL LEVEL. SOIL SHALL BE FIRMLY PLACED AROUND PLANTS AND MULCH. 2" OF SOIL AMENDMENTS SHALL BE ADDED TO EACH PLANT BED AS DIRECTED BY THE ENGINEER IN THE FIELD. CONTRACTOR SHALL COORDINATE WITH THE ENGINEER TO DETERMINE PROPER DELIVERY DATES AND QUANTITIES OF ANNUALS TO THE PLANT BED AREAS.

BEDDING PLANTS SHALL BE WATERED IN IMMEDIATELY FOLLOWING PLANTING OPERATION. NO PORTION OF PLANTING SHALL GO UN WATERED OVERNIGHT. (WATER IN SAME DAY AS PLANT INSTALLATION)







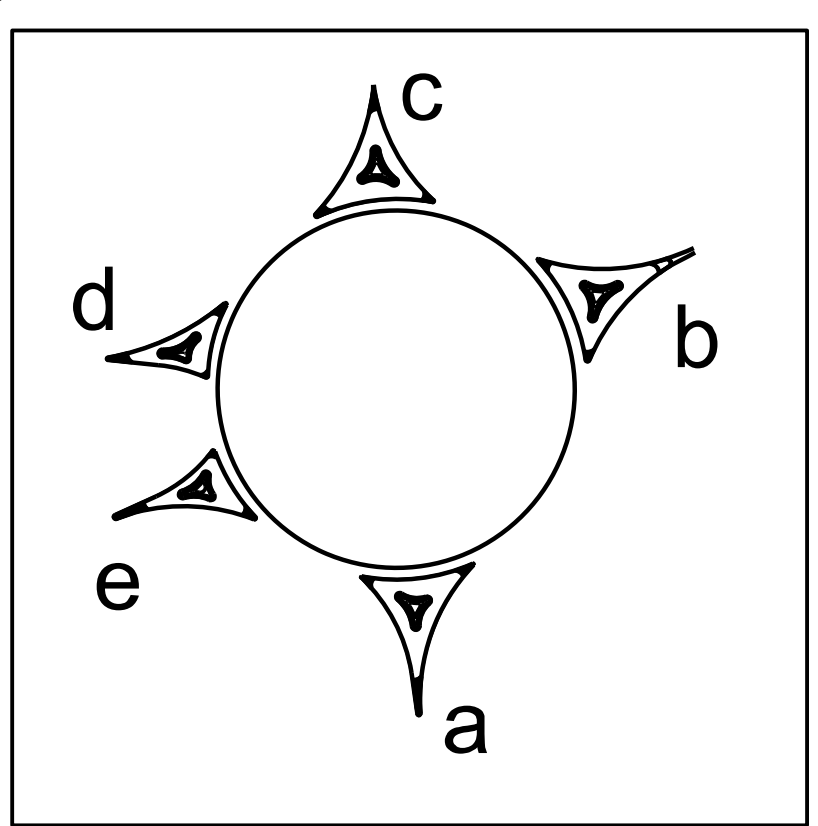

**PINEHURST TRAFFIC CIRCLE**

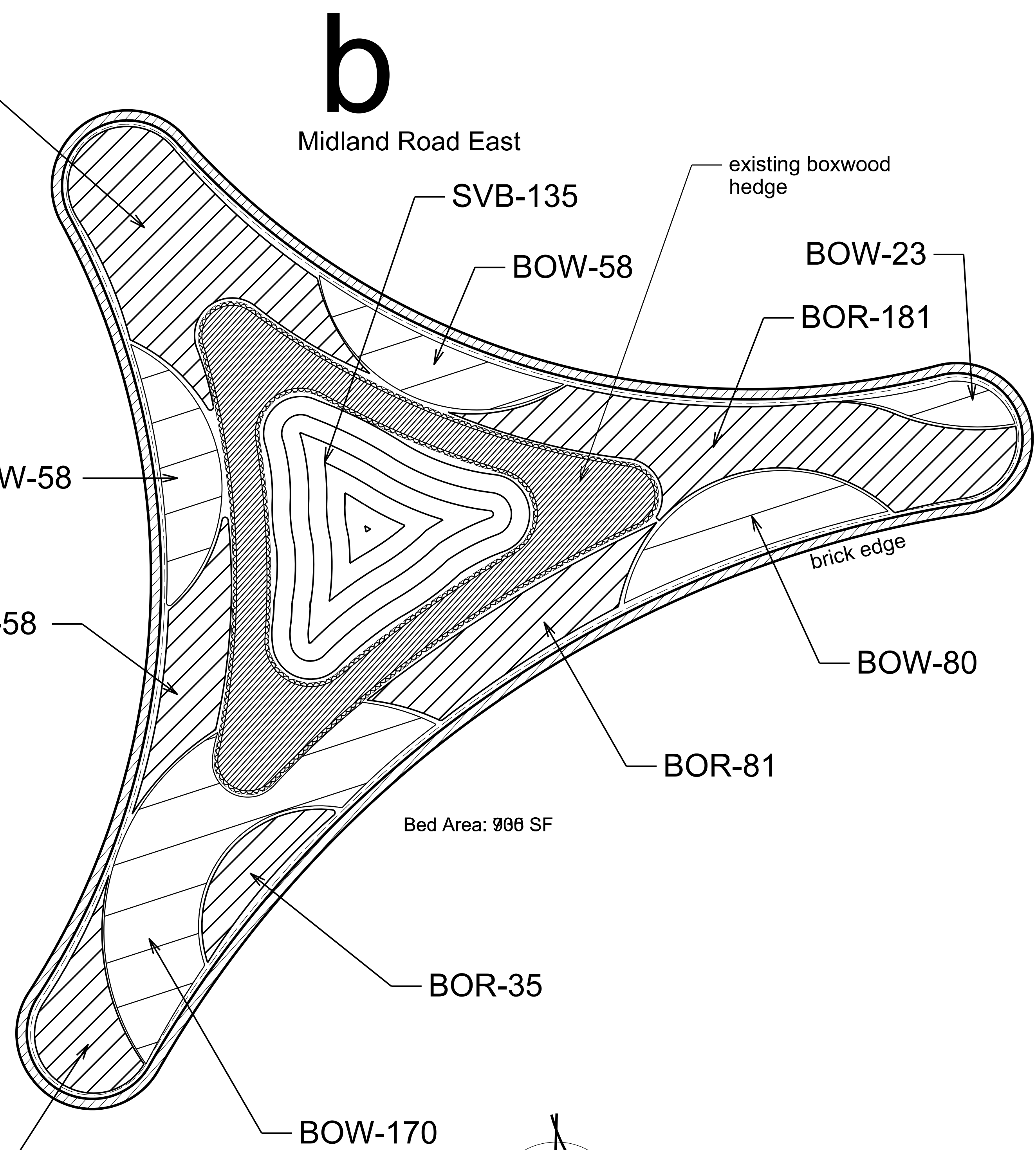
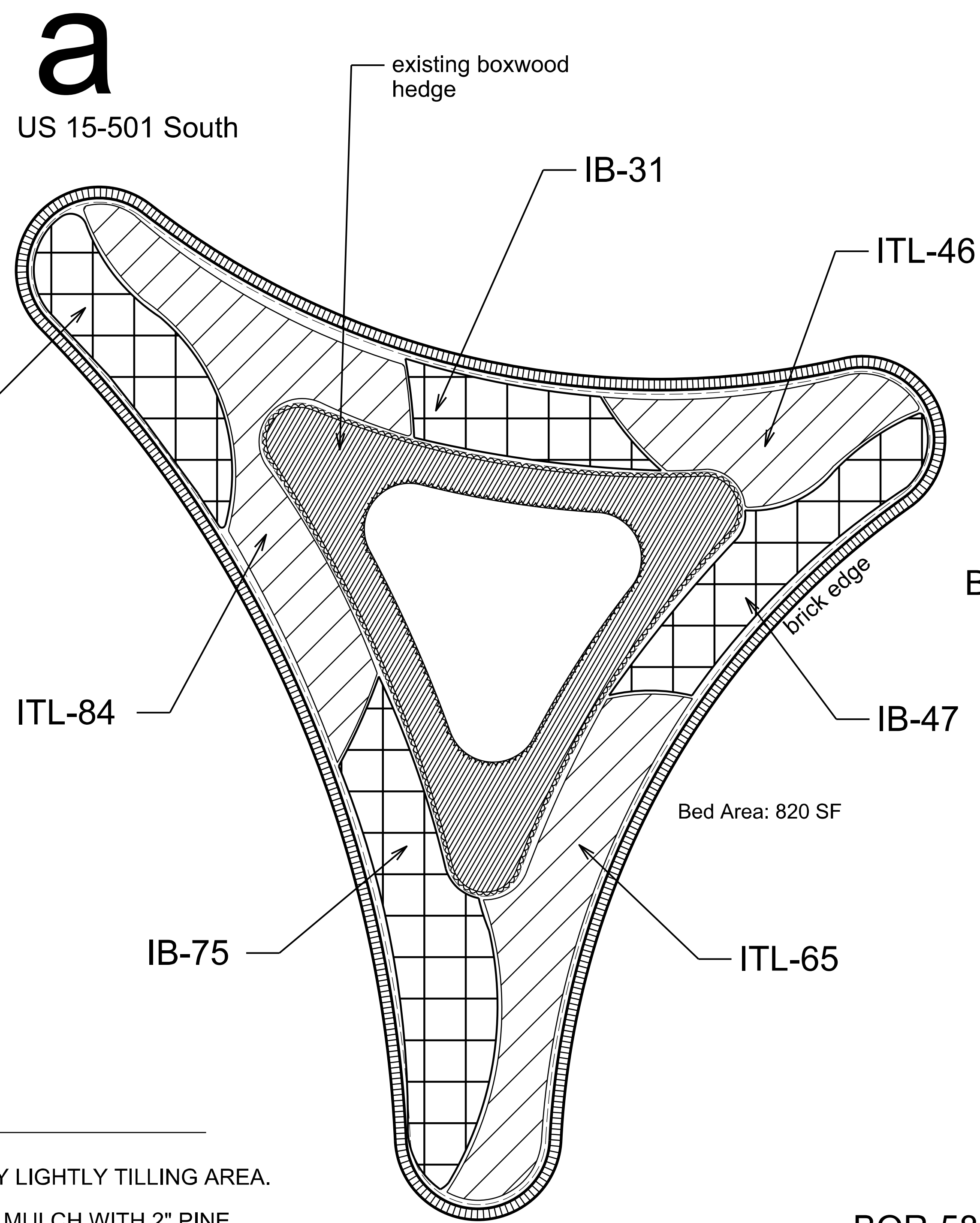

**NOTES**

- PREPARE PLANT BED BY LIGHTLY TILLING AREA.
- SUPPLEMENT EXISTING MULCH WITH 2" PINE BARK FINES.

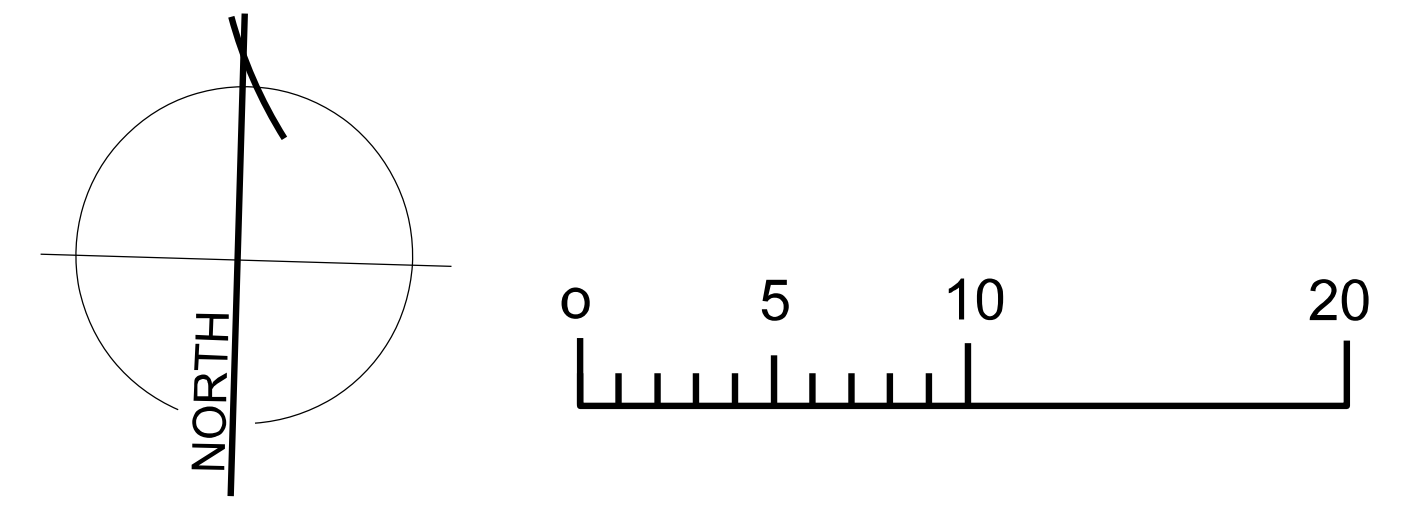

\$\$\$\$\$SYTIME\$\$\$\$\$  
 \$\$\$USERNAME\$\$\$

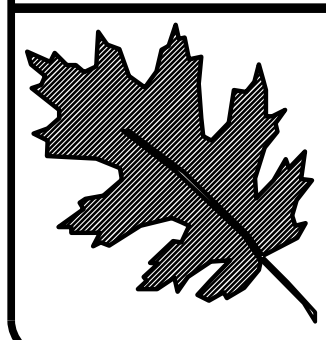

NCDOT - Roadside Environmental Unit  
 Landscape Design & Development  
 1557 Mail Service Center Raleigh NC 27699-1557  
 ph: 919-733-2920 fax: 919-733-9810  
[http://www.ncdot.org/doh/operations/dp\\_chief\\_eng/roadside/](http://www.ncdot.org/doh/operations/dp_chief_eng/roadside/)

**Moore & Lee County Plantings**  
 2024 US Open Summer Annuals  
 contract #:

re engineer  
**J. Lackey**

prel. design date :	Nov/2023
checked by & date :	
final design date :	

T.I.P. #	
WBS #	3708.3.26
FED I.D. #	
sheet no :	L4
total sheet no :	17

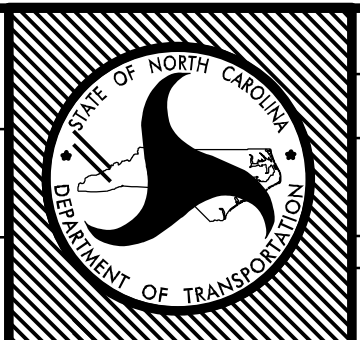

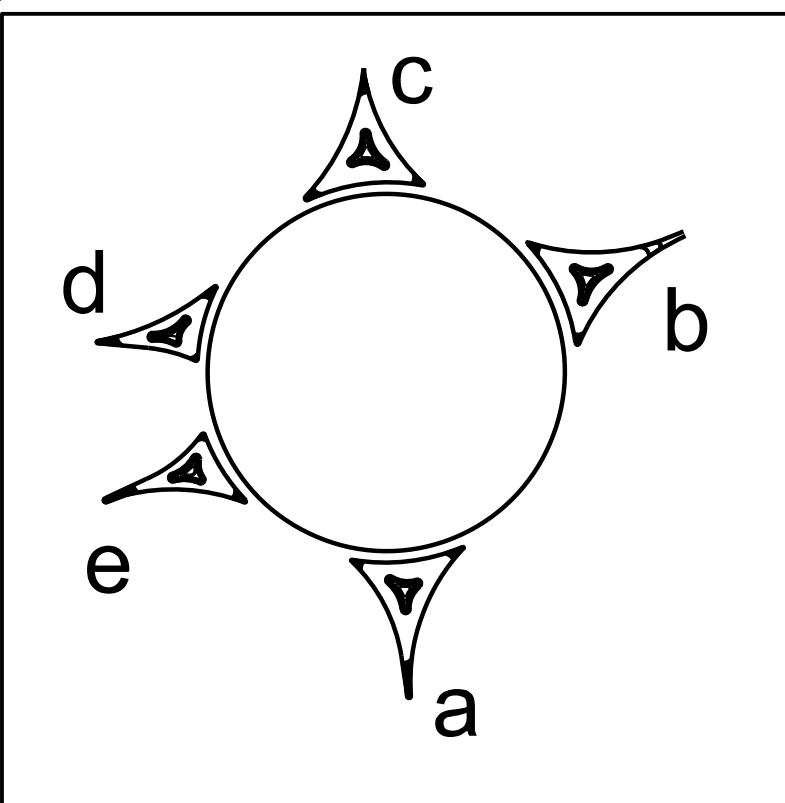

PINEHURST TRAFFIC CIRCLE

**C**

US 15-501 North

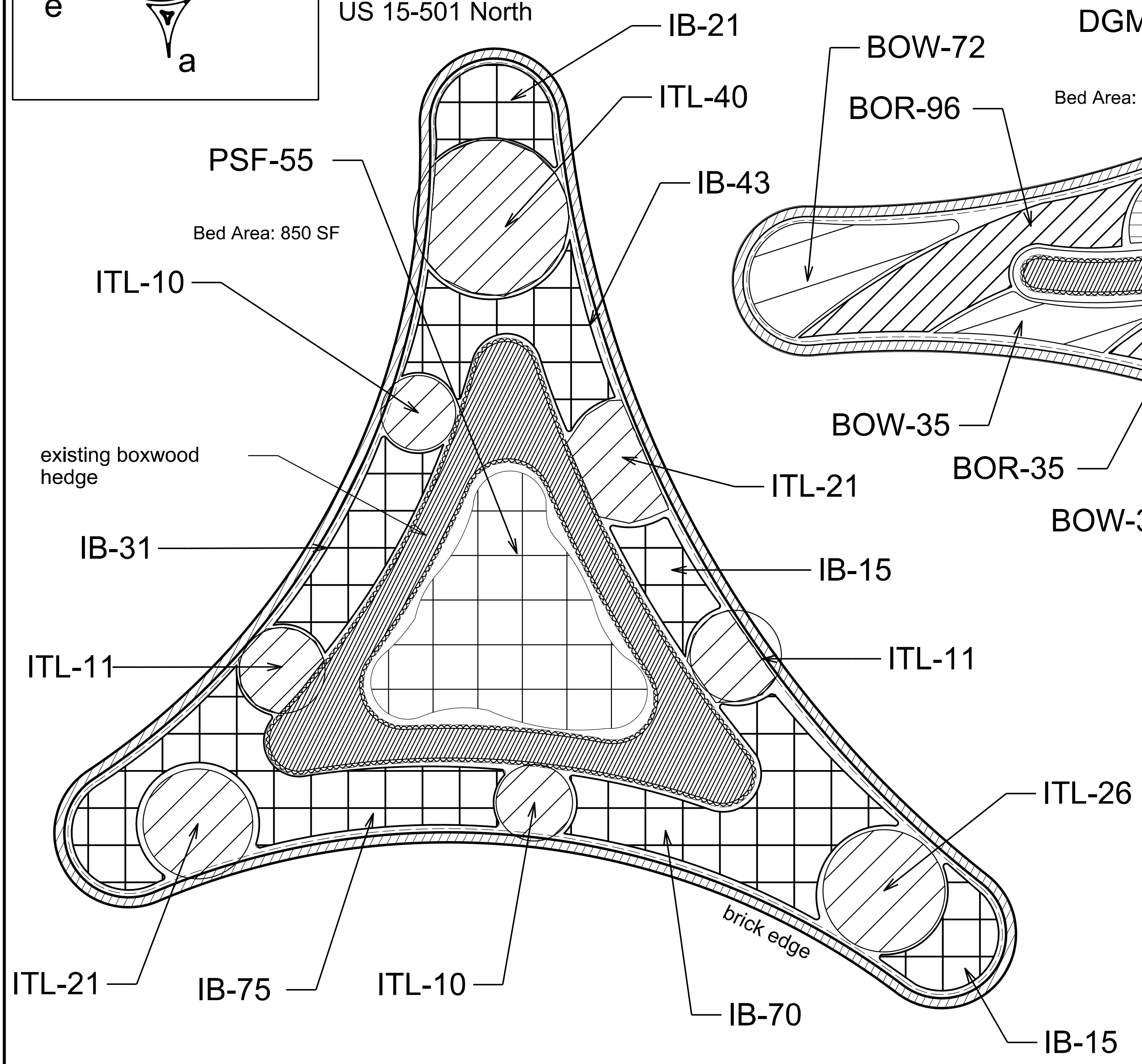

**d**

NC 211 West

DGM-120

Bed Area: 700 SF

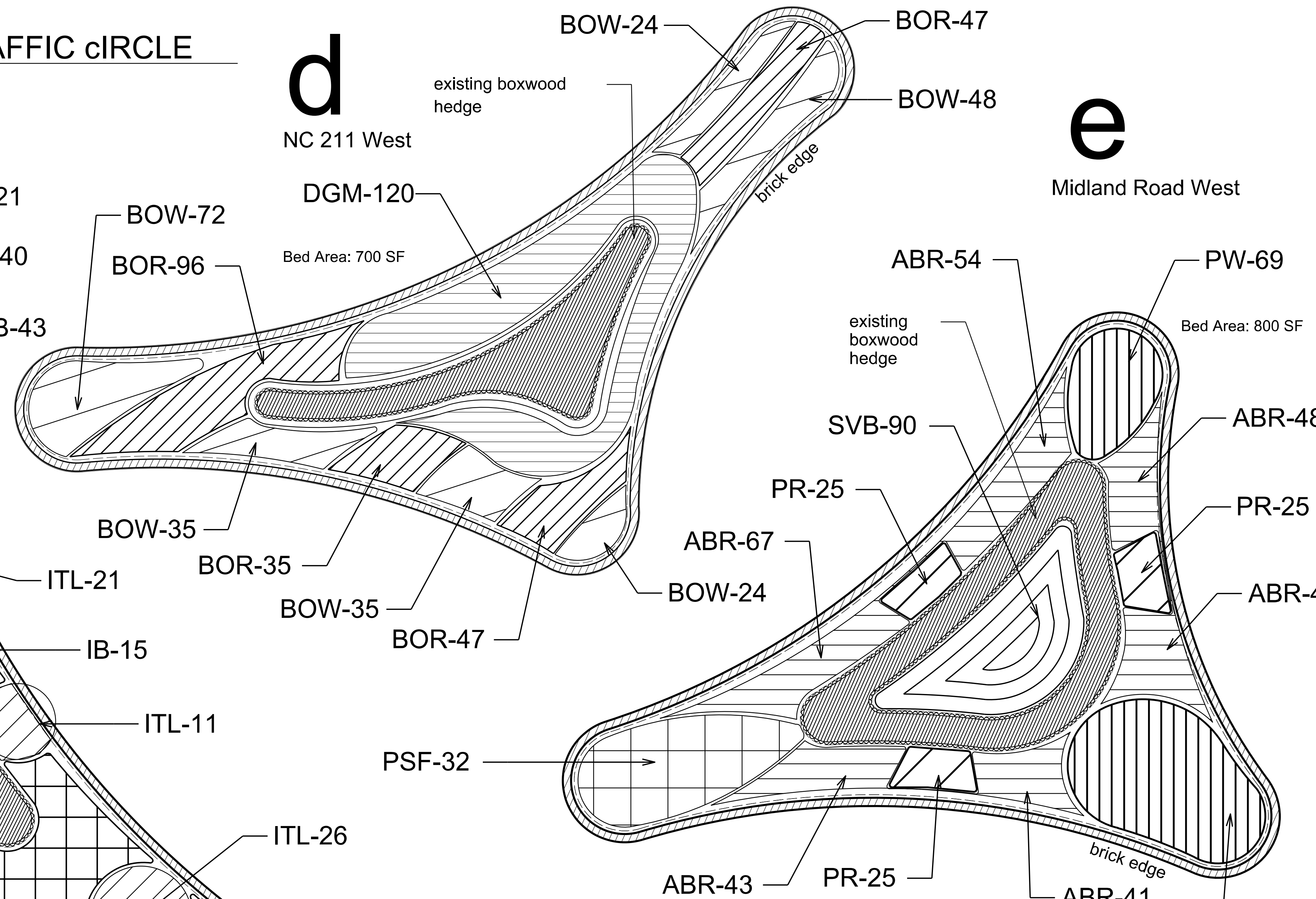

**e**

Midland Road West

Bed Area: 800 SF

**NOTES**

- PREPARE PLANT BED BY LIGHTLY TILLING AREA.
- SUPPLEMENT EXISTING MULCH WITH 2" PINE BARK FINES.

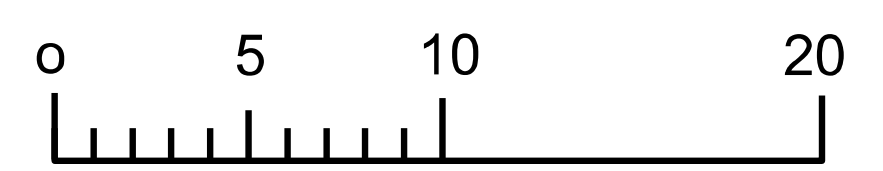
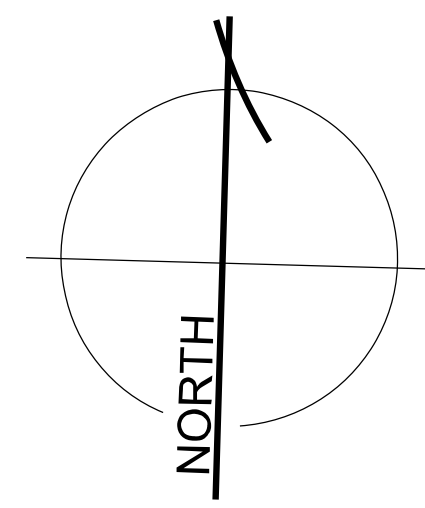

\$\$\$\$\$SYTIME\$\$\$\$\$  
\$\$\$\$\$USER\$\$\$\$\$

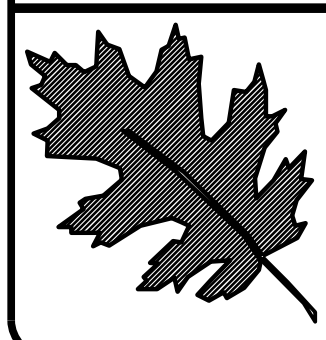

NCDOT - Roadside Environmental Unit  
Landscape Design & Development  
1557 Mail Service Center Raleigh NC 27699-1557  
ph: 919-733-2920 fax: 919-733-9810  
[http://www.ncdot.org/doh/operations/dp\\_chief\\_eng/roadside/](http://www.ncdot.org/doh/operations/dp_chief_eng/roadside/)

**Moore & Lee County Plantings**  
2024 US Open Summer Annuals

contract #:

re engineer  
**J. Lackey**

prel. design date :	Nov/2023
checked by & date :	
final design date :	

T.I.P. #	
WBS #	3708.3.26
FED I.D. #	
sheet no :	L5
total sheet no :	17

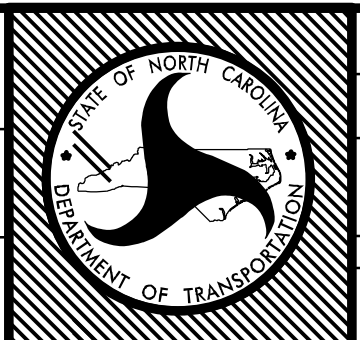



# US 1 @ US 15-501 SOUTH OF TRAMWAY

## NOTES

- Apply Herbicidal treatment in proposed bed area prior to bed preparation.
- Prepare plant bed by Tilling and integrating 6" of approved topsoil.
- Mulch annual plantings with 2" pine bark fines.

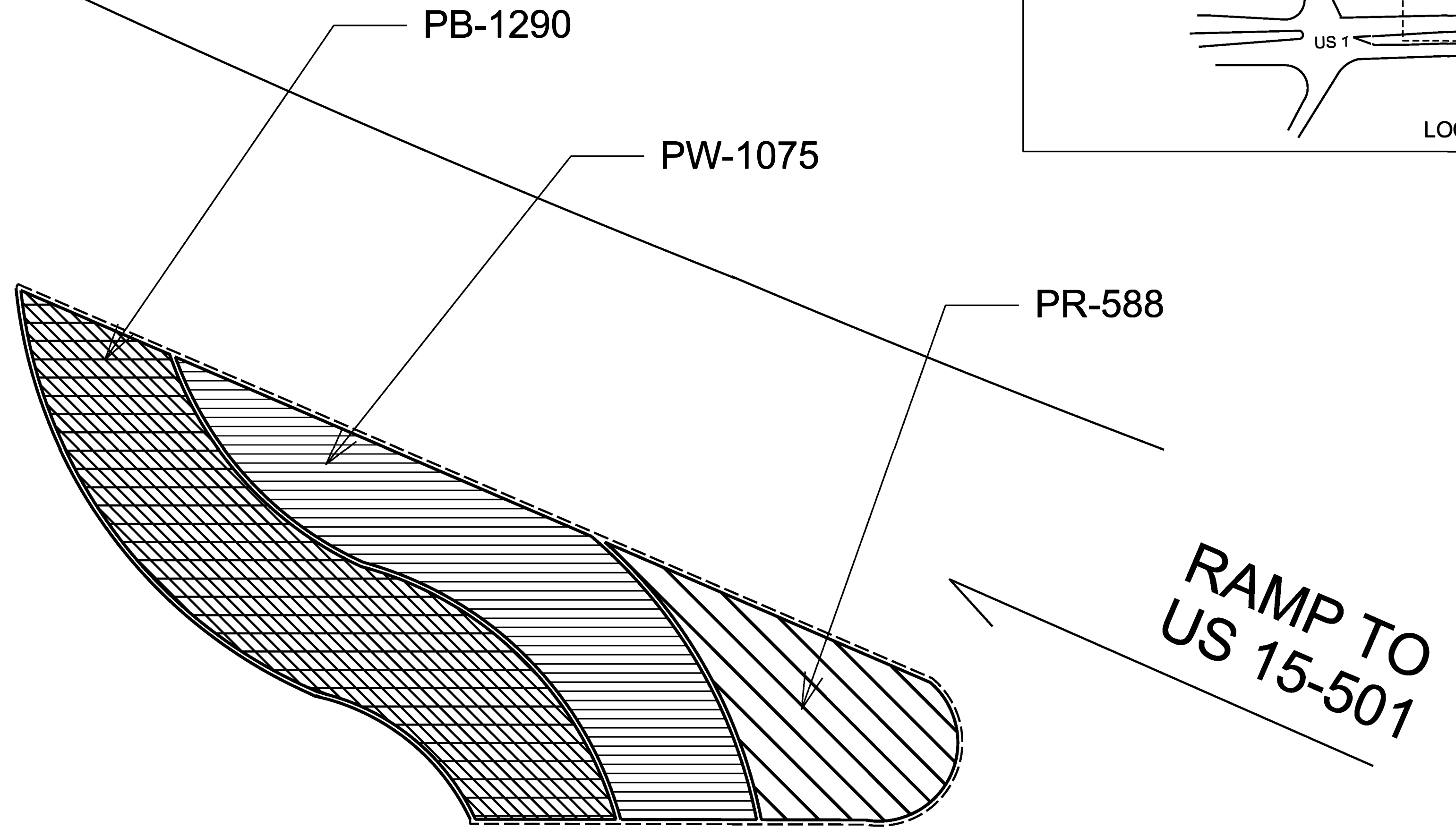
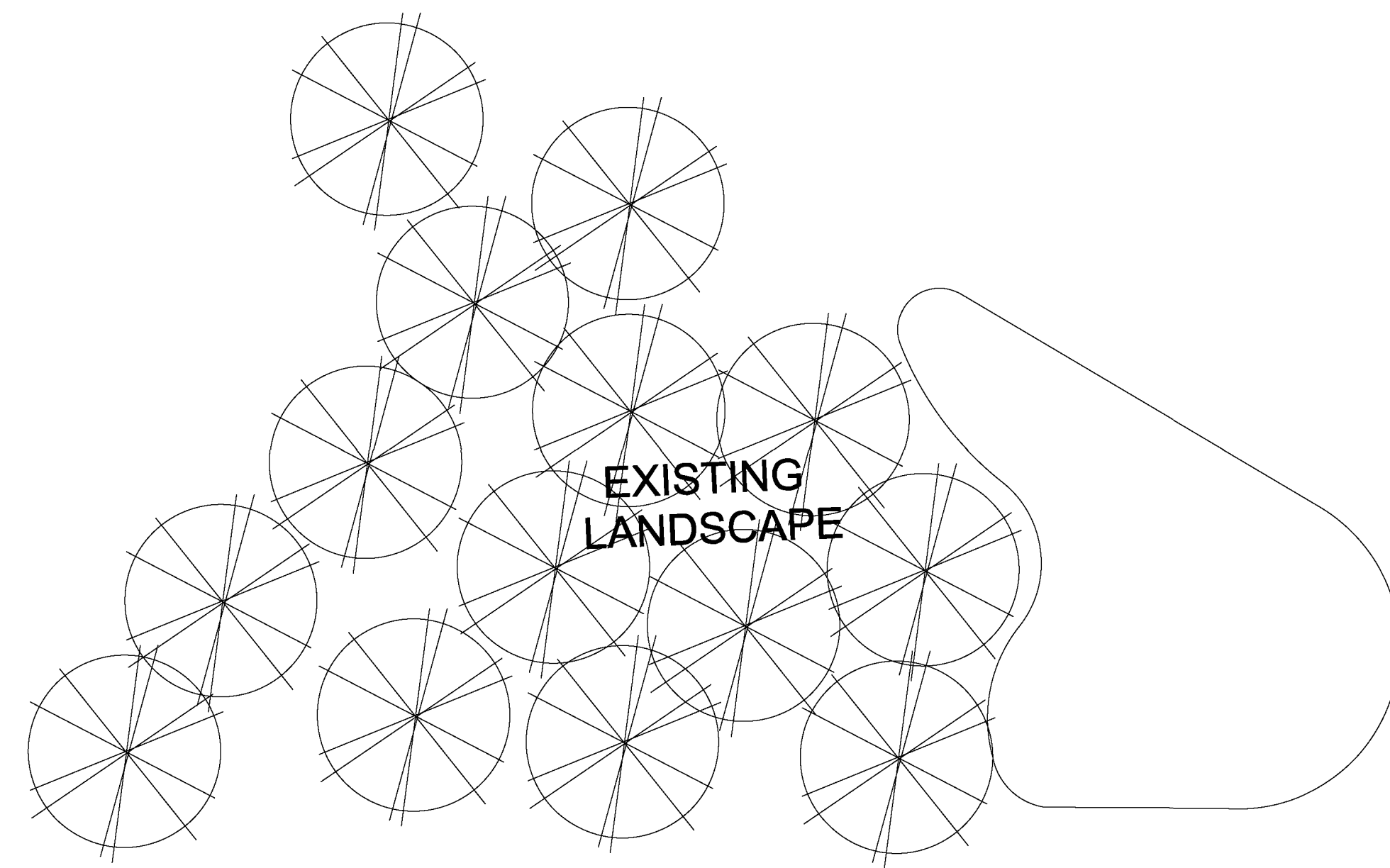
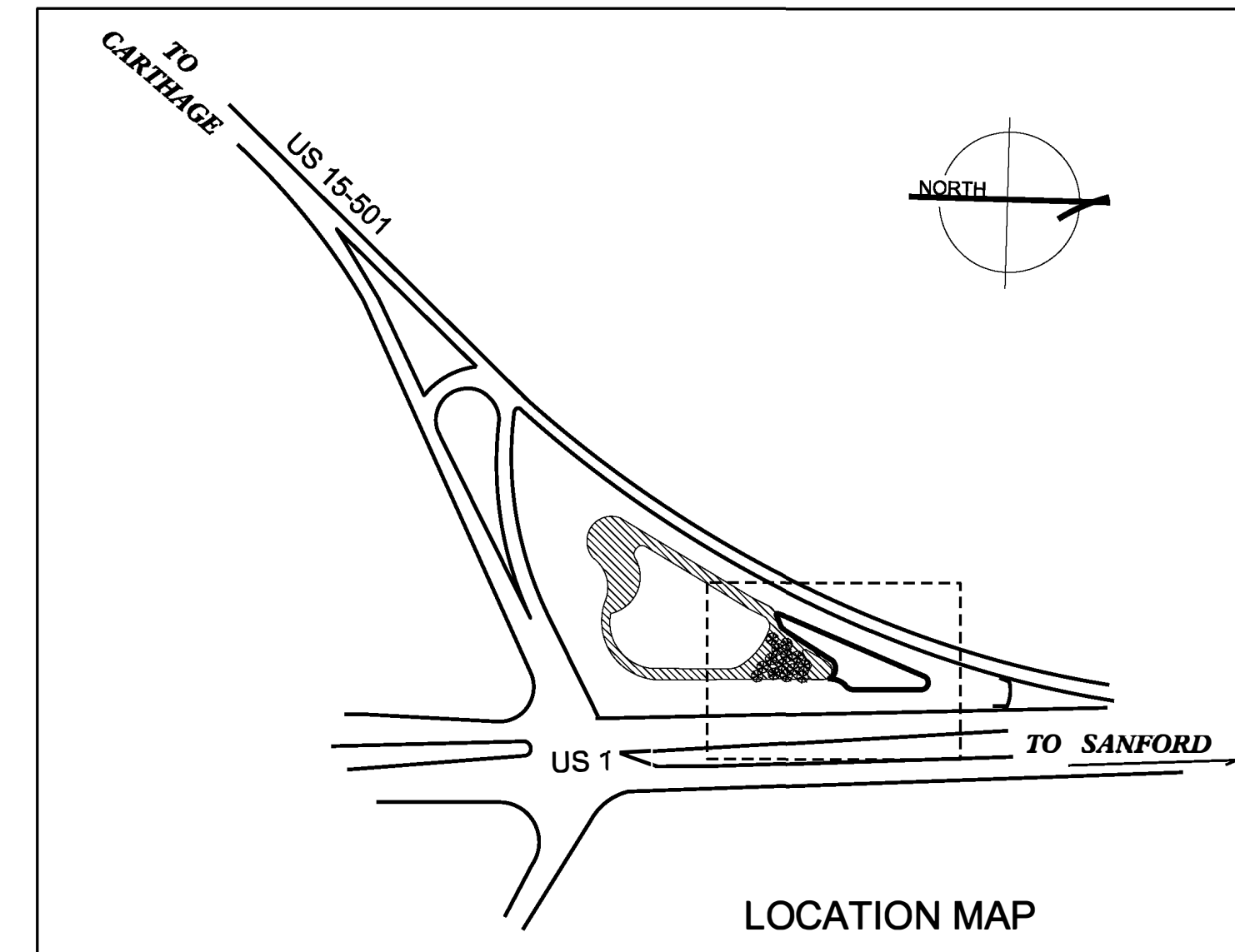

Annual Planting  
Bed Area: 3000 SF

### Plant Quantities

US 1 @ US 15-501

1704	EA	PB	Petunia 'Easy Wave Blue'	Easy Wave Blue Petunia	12" O.C.
780	EA	PR	Petunia 'Easy Wave Red'	Easy Wave Red Petunia	12" O.C.
2568	EA	PW	Petunia 'Easy Wave White'	Easy Wave White Petunia	12" O.C.

US 1

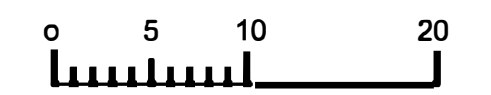

\$\$\$\$\$SYTIME\$\$\$\$\$  
\$\$\$\$\$SERIAL\$\$\$\$\$  
\$\$\$\$\$USER\$\$\$\$\$

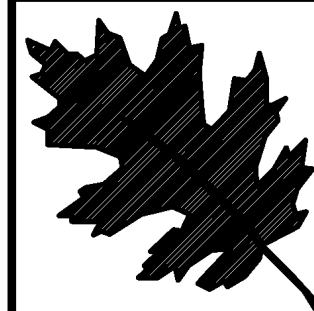

NCDOT - Roadside Environmental Unit  
Landscape Design & Development  
1557 Mail Service Center Raleigh NC 27699-1557  
ph: 919-733-2920 fax: 919-733-9810  
[http://www.ncdot.org/doh/operations/dp\\_chief\\_eng/roadside/](http://www.ncdot.org/doh/operations/dp_chief_eng/roadside/)

Moore & Lee County Plantings  
2024 US Open Summer Annuals

contract #:

re engineer

J. Lackey

sheet description:

prel. design date : Nov/2023

checked by & date :

final design date :

SPLIT @ US 1 & US 15-501

SOUTH OF TRAMWAY

ANNUAL PLANTING LAYOUT

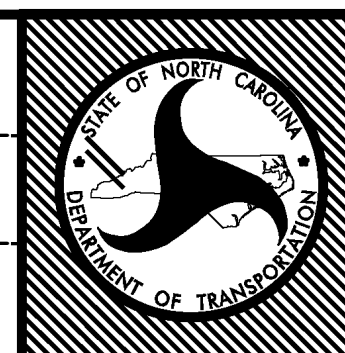

T.I.P. #  
WBS # 3708.3.26  
FED I.D. #  
sheet no : total sheet no :  
L6 17











# STAR DETAIL LAYOUT

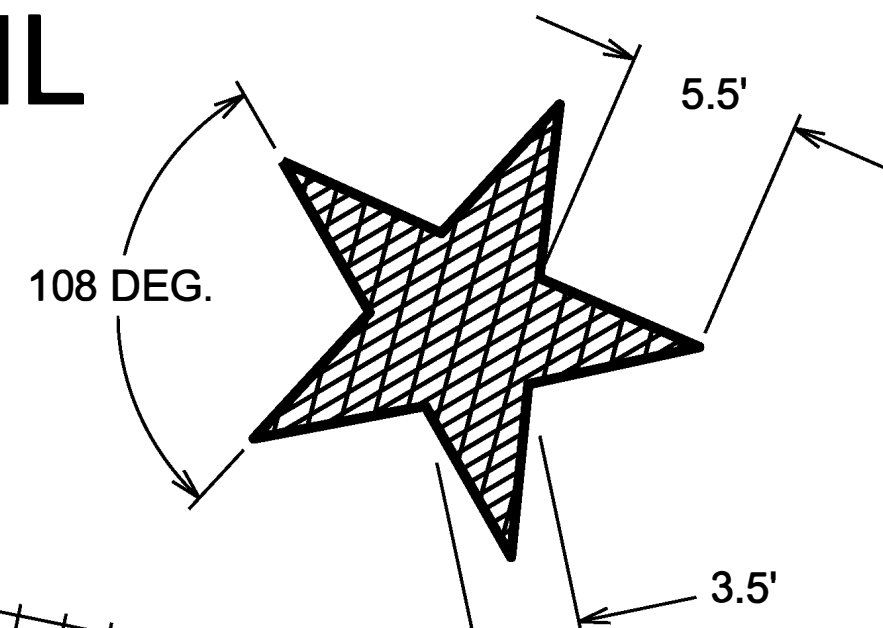

# NOTES

- Apply Herbicidal treatment in proposed bed area prior to bed preparation.
- Prepare plant bed by Tilling and integrating 6" of approved topsoil.
- Mulch annual plantings with 2" pine bark fines.
- Placement of plant bed may need adjusting in the field. Stake out planting prior to installation for NCDOT engineer review and APPROVAL.

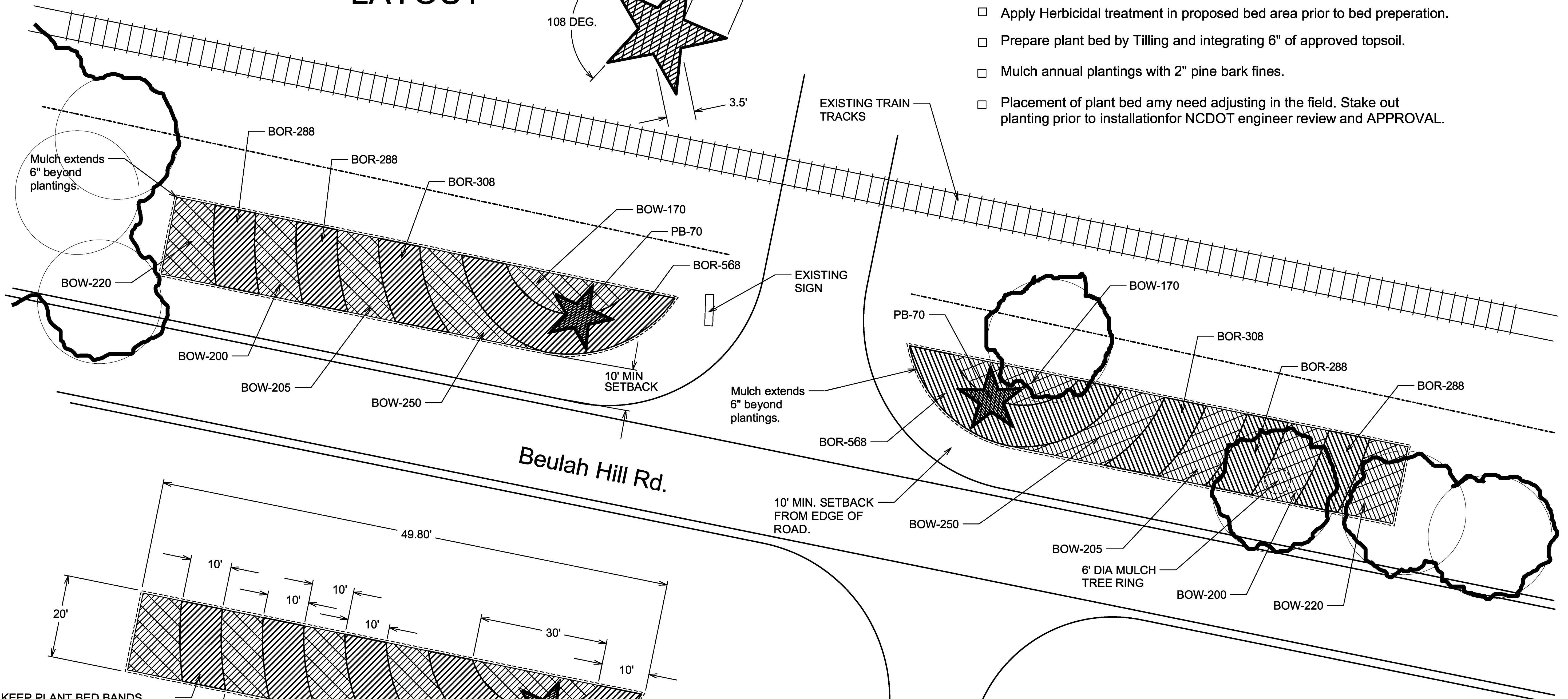

# BED LAYOUT DETAIL

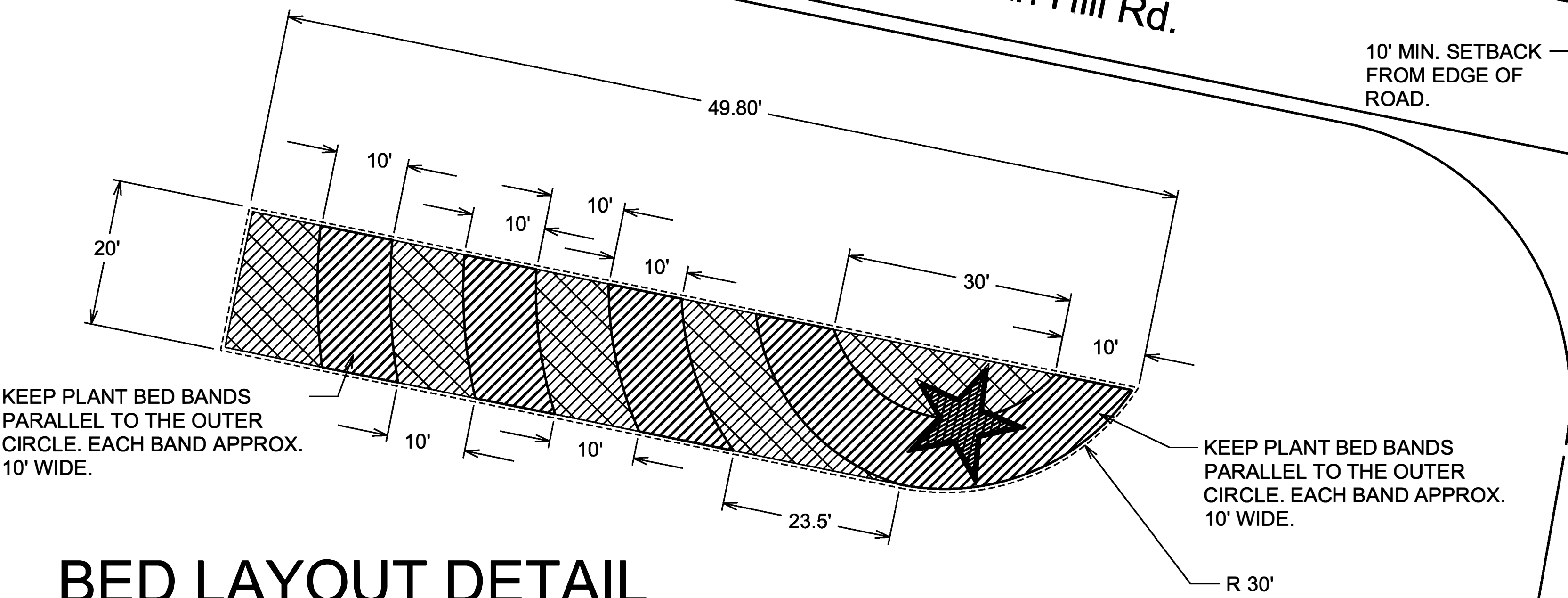

Plant Quantities

NC 5 @ HARNESS TRACK			
2904	EA	BOR	Begonia 'Super Olympic Red' Super Olympic Red Begonia 12" O.C.
2762	EA	BOW	Begonia 'Super Olympic White' Super Olympic White Begonia 12" O.C.
186	EA	PB	Petunia 'Easy Wave Blue' Easy Wave Blue Petunia 12" O.C.

\$\$\$\$\$\$SYTIME\$\$\$\$\$  
 \$\$\$\$\$\$SERIAL\$\$\$\$\$  
 \$\$\$\$\$\$DATE\$\$\$\$\$  
 \$\$\$\$\$\$USER\$\$\$\$\$  
 \$\$\$\$\$\$NAME\$\$\$\$\$



NCDOT - Roadside Environmental Unit  
 Landscape Design & Development  
 1557 Mail Service Center Raleigh NC 27699-1557  
 ph: 919-733-2920 fax: 919-733-9810  
[http://www.ncdot.org/doh/operations/dp.chief\\_eng/roadside/](http://www.ncdot.org/doh/operations/dp.chief_eng/roadside/)

**Moore & Lee County Plantings**  
 2024 US Open Summer Annuals  
 contract #:

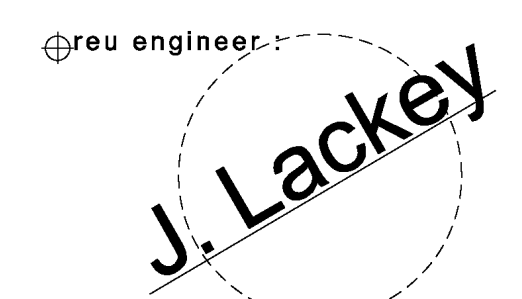

prel. design date : Nov/2023  
 checked by & date :  
 final design date :

NC 5 @ Harness Track Rd.  
 ANNUAL PLANTING LAYOUT



T.I.P. #	
WBS #	3708.3.26
FED I.D. #	
sheet no :	total sheet no :
L11	17



# IRRIGATION SPECIFICATIONS

\*Irrigation contractor must be licensed by the NCICLB under chapter (2008-177, S.1; 2013-383, S.3).

\*All materials may be of comparable manufacture and performance to the brand listed.

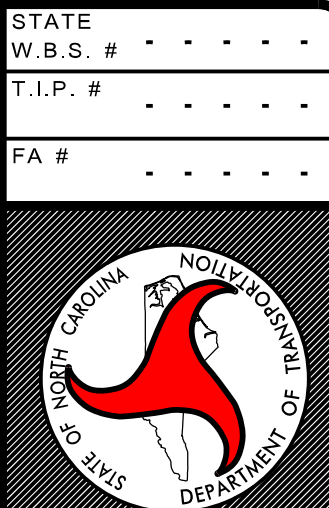

AESTHETICS ENGINEERING SECTION  
 NCDOT ROADSIDE ENVIRONMENTAL UNIT  
 1557 MAIL SERVICE CENTER  
 RALEIGH NC 27699  
 919-733-2920

PLAN : 2024 US Open  
 Annual Plantings Irrigation  
 PROJECT DESCRIPTION :  
 Blake Blvd & NC 5 at Pinehurst Fair Barn

DESIGNED BY:	
K. COOPER, PLA	
SHEET:	
IRRIGATION SPECIFICATIONS	
DATE	
11/17/2023	
SCALE	
SHEET #	OF
I-1	6

ESTIMATED IRRIGATION QUANTITIES	
Meter Locations - 2	
Backflow Preventers - 2	
Battery Powered Controllers - 2	
Spray Zones Valves - 6	
Main Line Pipe - 375 LF	
Lateral Pipe - 1,231 LF	
Sleeve Pipe - 84 LF	
Spray Heads (Total):	
8' r - 55	
10' r - 74	

Quantities are estimated based on design drawings. Refer to plans for any discrepancies. Plans take priority over these estimated quantities. Estimated quantities do not cover all materials necessary for installation. Quantities may be adjusted slightly due to site conditions, specific irrigation equipment, and implementation.

## GENERAL NOTES

- The irrigation design provided in the plans is schematic in nature, and the irrigation contractor may be required to make minor adjustments in the field as necessary. These adjustments shall be made at no additional cost to the owner and shall be made only after notification is made to the owner (NCDOT).
- The contractor(s) shall familiarize themselves with the site so they are aware of any special conditions that may exist that could affect their bid proposal and shall hereafter be responsible for all costs incurred in relation to the installation.
- Prior to the start of any work, the contractor shall verify the available static water pressure (PSI) and gallons per minute (GPM) at the point of connection to the water source. Any replacements, relocation, or additional materials required as a failure to check the PSI and GPM shall be done at the contractor's expense.
- Place valves and boxes in plant beds wherever possible.
- The contractor is to minimize disturbance in sod areas. Cut and replace sod when necessary.
- Place pressure reducing valves in discreet locations.
- All irrigation products are to be Hunter, Rainbird, Toro, or an equivalent brand.
- If there is an existing system in place, be sure to use irrigation components that are consistent with the existing system.
- The contractor is responsible for providing as built plans to the owner (NCDOT) at the time of project approval. The plans shall be clear, concise, and show all elements of the irrigation system, the location of all equipment, irrigation lines, numbered zones, controller(s), heads, and valves.
- The irrigation contractor shall, in the presence of the Division Roadside Environmental Engineer and the municipality's employees responsible for the maintenance of the system, meet the following obligations:
  - Explain the complete operation of the system.
  - Be available to answer any questions that system operators may have during the first year of operation.
  - Winterize the system during November of the first year of operation.
  - Reenergize the irrigation system in April the following year, and prepare check the system for full operation.

## 24 VAC CONTROLLER WIRING

- All 24 VAC control wiring shall be single strand copper wire with polyethylene PE direct burial insulation rated for 300 VAC. Valve common wires shall have white insulation while hot wires shall have red insulation. Both the common and hot wires shall be #14 AWG. Valve wiring shall follow mainline piping where feasible and shall be laid in the bottom of the trench line with the mainline piping. Wiring shall be bundled and taped at intervals of approximately ten feet. All wiring shall be installed in accordance with local code requirements.
- Wire splices shall be kept to an absolute minimum. Where major concentrations of splices are necessary, they shall be placed in an approved high-density polyethylene (HDPE) valve box with cover installed at grade level. Splices at valve locations shall be made inside of the valve box. All splice locations shall be noted on the as-built plan.
- Wire runs shall be installed with enough slack and/or expansion loops to prevent excessive strain due to thermal contraction.
- All wire splices shall be made using UL approved direct burial connectors and waterproof materials. All electrical work shall be installed according to code.

## BACKFLOW PREVENTION

- The reduced pressure backflow preventer assembly shall be the responsibility of the irrigation contractor. The backflow shall be 1" in size. The backflow assembly shall be installed downstream of the irrigation meter. The unit must be installed in accordance with all local and state code requirements and shall have an approved lockable cover.

## CONTROLLER W/ BATTERY POWERED TIMER

- The controller shall be a Hunter, Rainbird, Toro or equivalent modular unit. The controller shall incorporate a 24 VAC with the approximate location shown on the plans. Location must be approved by the NCDOT Environmental Roadside Engineer.
- The battery operated controller is to be placed in high-density polyethylene (HDPE) valve boxes with covers.
- All 120 VAC wiring shall be installed in accordance with all applicable electrical code requirements.
- The contractor shall install a wired rain sensor that is compatible with the make and model of the controller. The rain sensor mount is to be painted a dark hunter green in order to blend into the landscape. Place the sensor in an uncovered area of the bed that's being irrigated.

## ELECTRIC CONTROL VALVE

- Location of AC powered electric remote-control valve with flow-control feature
- Valves shall be Hunter, Rainbird, or Toro.
- All remote control valves shall be installed in Carson valve boxes with lids mounted at grade level. Single valves may be installed in a Carson model #910-1 valve box with cover, while multiple valves (up to, 2 - 1" valves or 1 - 1 1/2") shall be installed in Carson model #1419-1 box with #1419-2 cover.

## HEADS

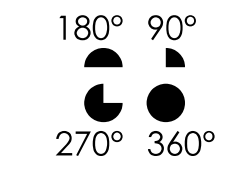

- Hunter, Rainbird, or Toro Pop-up Spray heads fitted with adjustable arc nozzles for 8' and 10' radius heads
- All heads in turf areas shall have a 6" pop-up stroke and heads in plant beds shall have 12" pop-up stroke. For annual plant beds, use a 12" pop-up stroke body. If installed with less than 1/3 of the sprinkler body exposed above grade, it shall be installed on polyethylene flex swing joint poly pipe fitted with elbows (3/8" insert by 1/2" M.P.T. and/or 3/8" insert by 3/4" M.P.T.)
- If greater than 1/3 of the sprinkler body is exposed, then the 6"-12" pop-up head shall be mounted on a schedule 40 PVC riser as described below in relation to mounting shrub head models. In mounting 6"-12" pop-up heads on shrub type risers, care shall be taken to install the head in such a manner that the surrounding plant material (planned or existing) will hide the body of the sprinkler.
- All pop-up irrigation heads designed adjacent to curbs or pavement shall be installed with a clearance of 6" from the edges of all paved areas to provide for edging and maintenance operations. Heads installed on shrub risers or with the top of the head more than 2" above the grade shall be installed with a minimum 6" clearance from paved areas.
- All threaded pipe connections shall be assembled using Teflon thread sealing tape.

## HEAD RADII

- The irrigation contractor shall adjust the radius and throw of each spray head to provide optimum coverage while minimizing overspray onto hardscapes or buildings. Adjust heads to eliminate dry spots. Coverage must be head to head.
- Approximate arc and radius of individual spray head coverage shall be as illustrated. Individual head or nozzle model numbers will be dependent upon the required specifications.

## SLEEVES

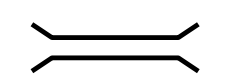

- Sleeve pipe shall be 4" Sch 80 PVC. The irrigation contractor shall coordinate their construction with the landscape contractor to insure proper installation of the irrigation system around the landscape plantings.

## PIPE

- PR 200 PVC Lateral Piping
- Size of pipe to be a minimum of 1"
- Minimum depth of cover over lateral piping to be 12". Lateral pipe sizing schedule and summation of gallonage demand on a particular branch of pipe within a control section shall be determined by using the gpm for a nozzle based on a 60 psi base head pressure and full radius at that pressure as reported in the manufacturer's product catalog.
- Sch 40 Main Line Piping.
- The main line shall be installed so that it doesn't conflict with existing utilities.
- Size of pipe to be a minimum of 1 1/2"
- Depth of cover of mainline piping to be a minimum 18".
- Piping shall be schedule 40 solvent weld PVC pipe with schedule 40 PVC solvent weld fittings unless otherwise noted.
- The contractor shall take all precautions necessary to avoid damaging existing plantings and their roots during the installation of the irrigation system and shall coordinate their efforts with the landscape contractor to optimize the efficiency and the aesthetic quality of the installation.

## WATER SUPPLY/METER

- The meter is 1" in size. Since the water supply for the system will be potable water, the contractor will be required to install a backflow prevention device which will be located downstream of the irrigation meter.
- This irrigation system shall be capable of delivering 33 gpm at minimum with one control station operating at a time at 60 psi at the base of the head for optimum performance of the irrigation system.



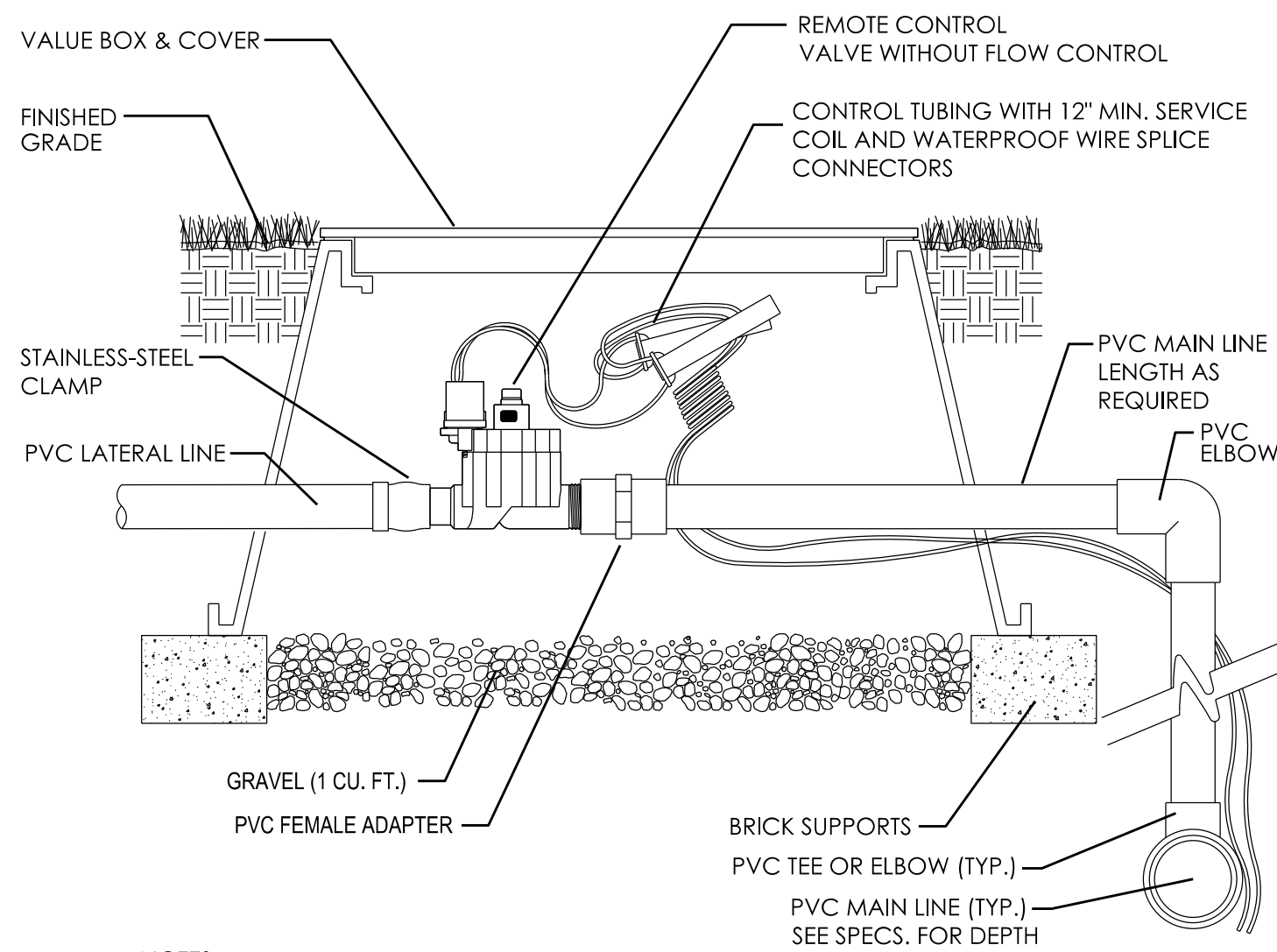

NOTES:  
 1. INSTALLATION TO BE COMPLETED IN ACCORDANCE WITH MANUFACTURERS SPECIFICATIONS.  
 2. DO NOT SCALE DRAWINGS.

1 VALVES & BOX  
(NOT TO SCALE)

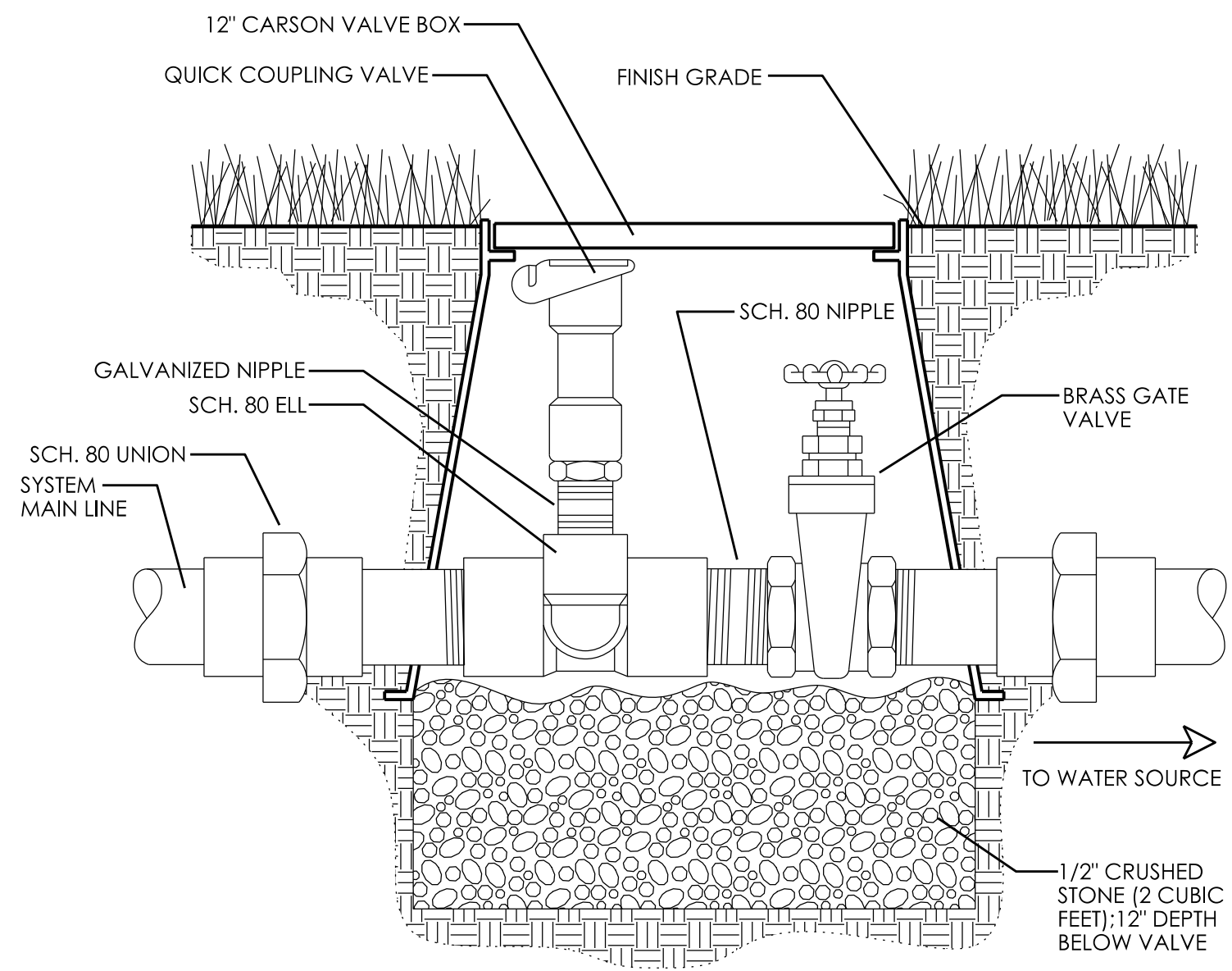

2 WINTERIZATION ASSEMBLY  
(NOT TO SCALE)

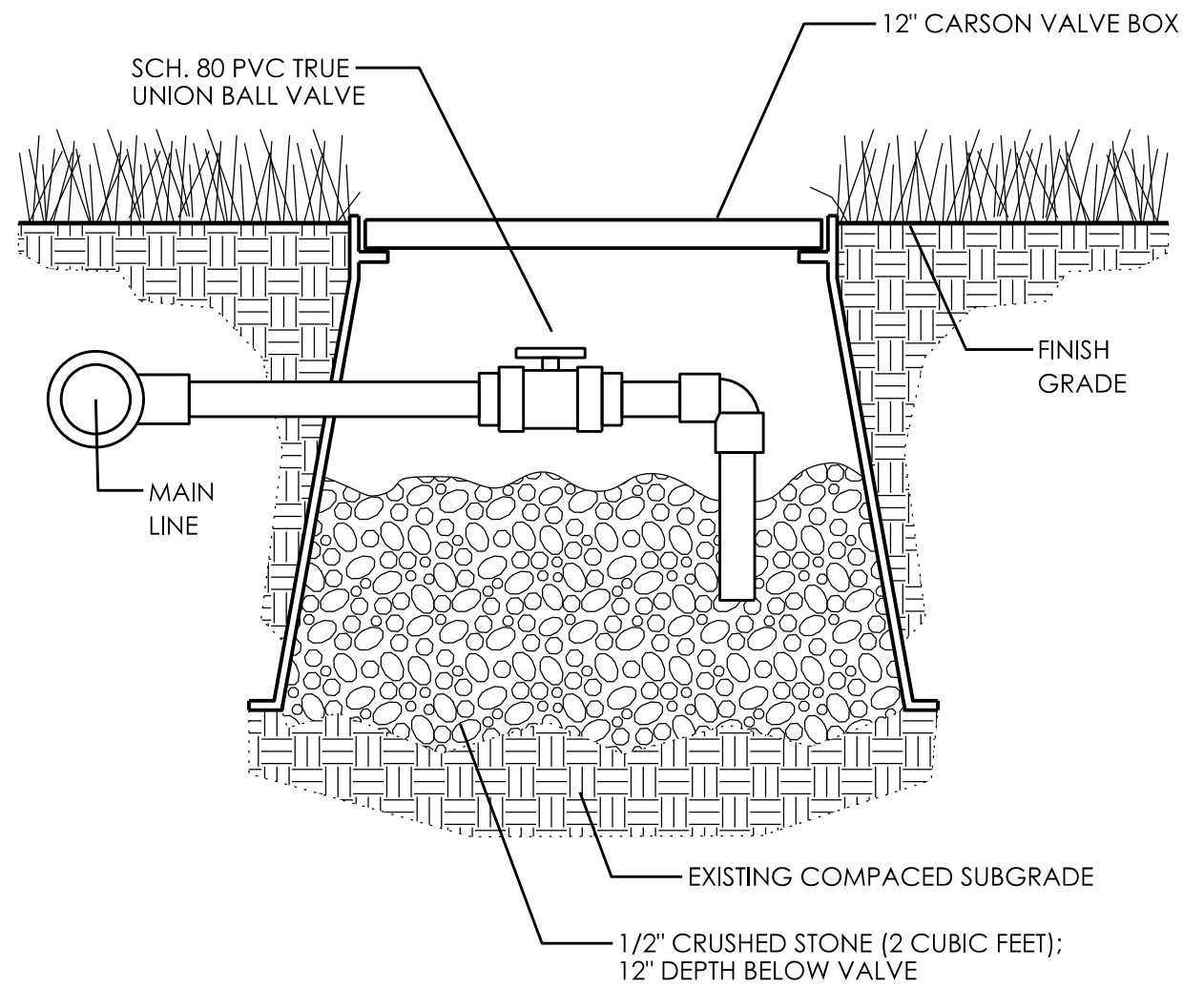

3 MANUAL DRAIN VALVE  
(NOT TO SCALE)

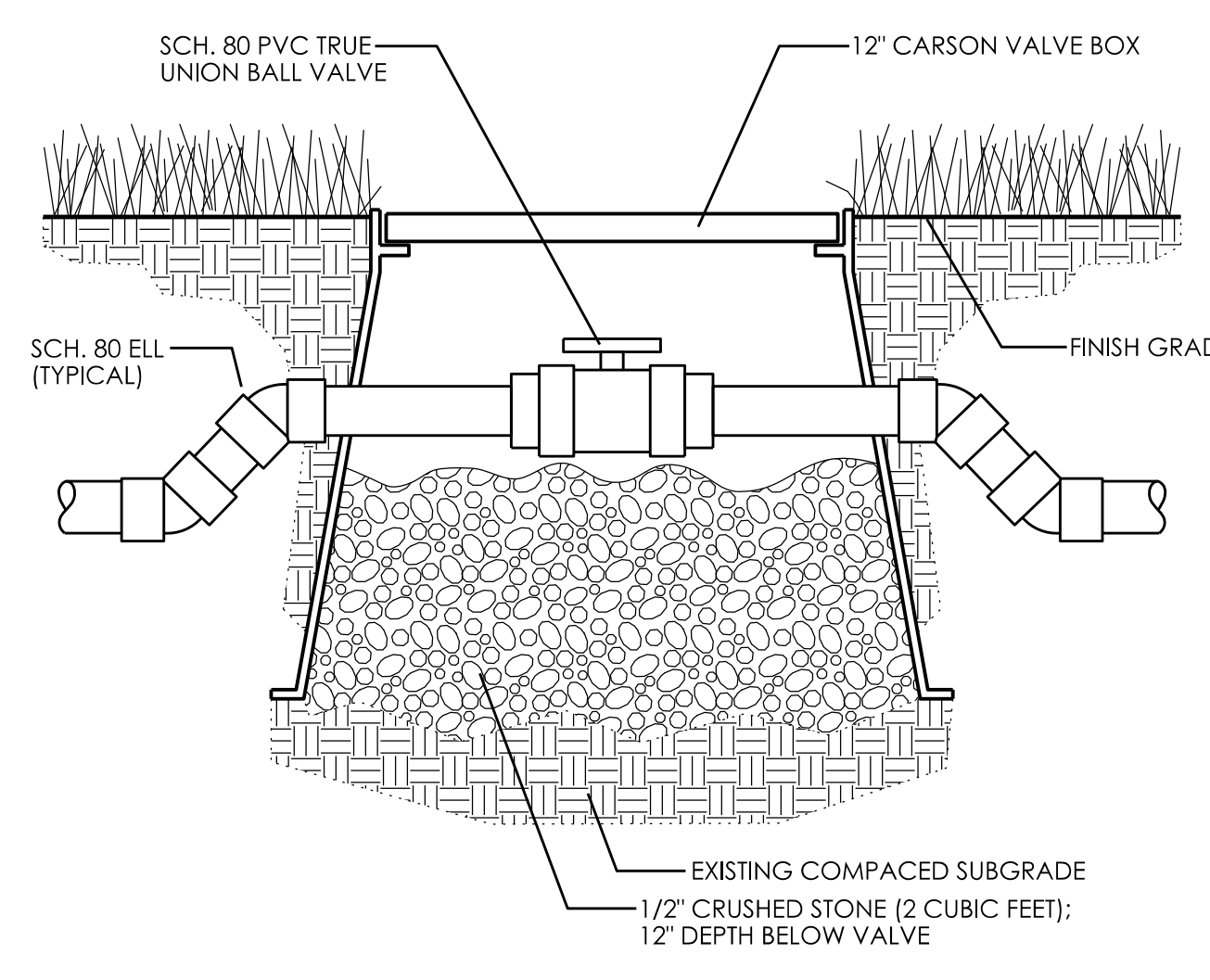

4 MANUAL SHUT-OFF VALVE  
(NOT TO SCALE)

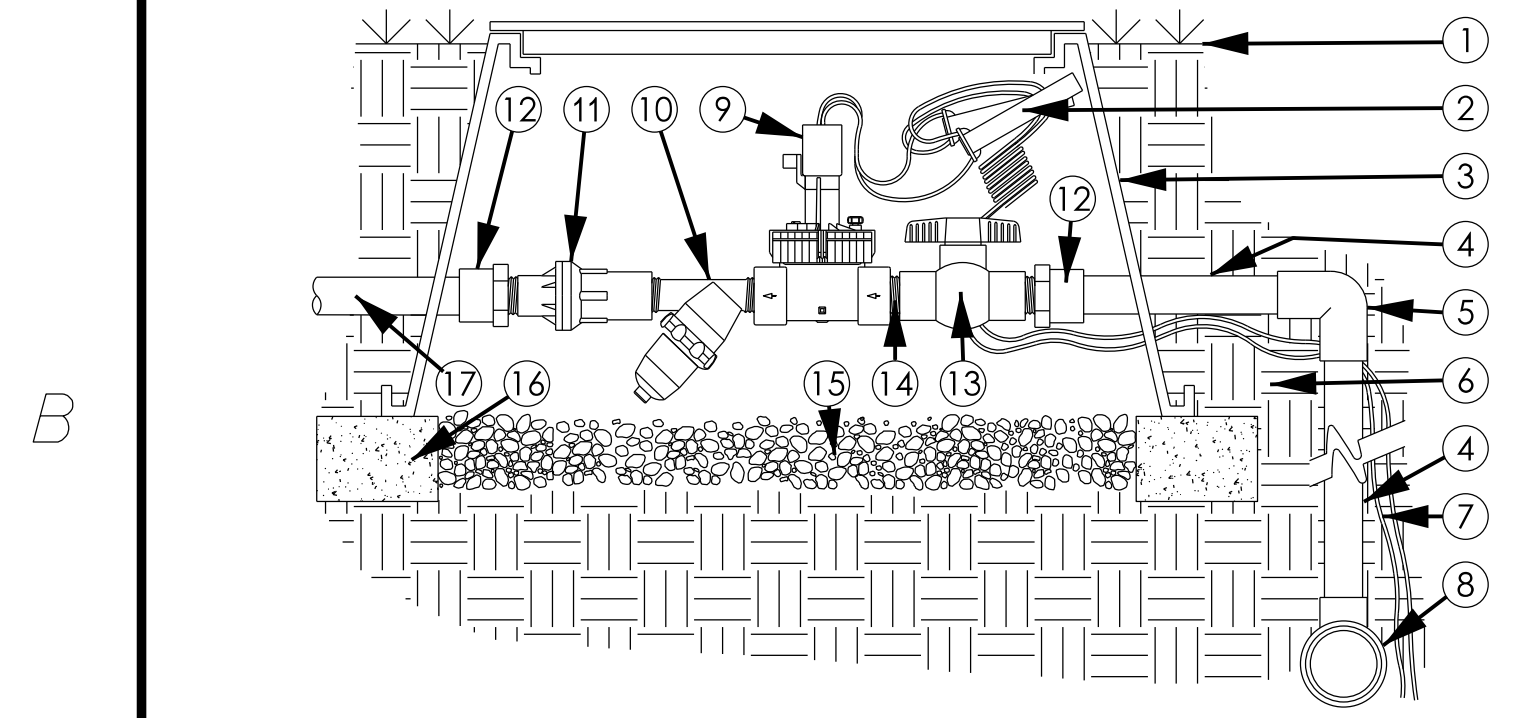

LEGEND

1. FINISHED GRADE	10. MESH SCREEN FILTER WITH FLUSH CAP
2. WATERPROOF DRY SPLICE CONNECTORS	11. ADJUSTABLE PRESSURE REGULATOR
3. 12" VALVE BOX WITH COVER	12. PVC SCH 40 FEMALE ADAPTER
4. PVC LATERAL LINE	13. MANUAL VALVE
5. SCH 40 PVC 90° ELL JOINT	14. PVC SCH 40 TRANSITION NIPPLE
6. NATIVE SOIL PER SPECIFICATIONS	15. WASHED GRAVEL SUMP (MIN. 3")
7. CONTROL WIRES TO CONTROLLER	16. BRICK SUPPORTS
8. PVC MAINLINE FITTING	17. LATERAL LINE TO DRIP SYSTEM
9. REMOTE CONTROL VALVE	

NOTES:  
 1. INSTALLATION TO BE COMPLETED IN ACCORDANCE WITH MANUFACTURERS SPECIFICATIONS.  
 2. DO NOT SCALE DRAWINGS.

5 DRIP ZONE ASSEMBLY  
(NOT TO SCALE)

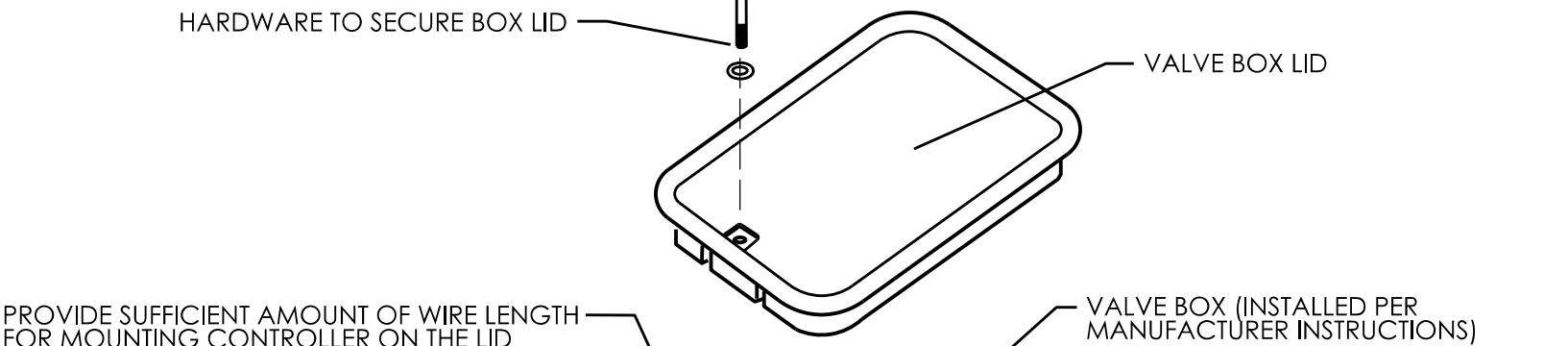
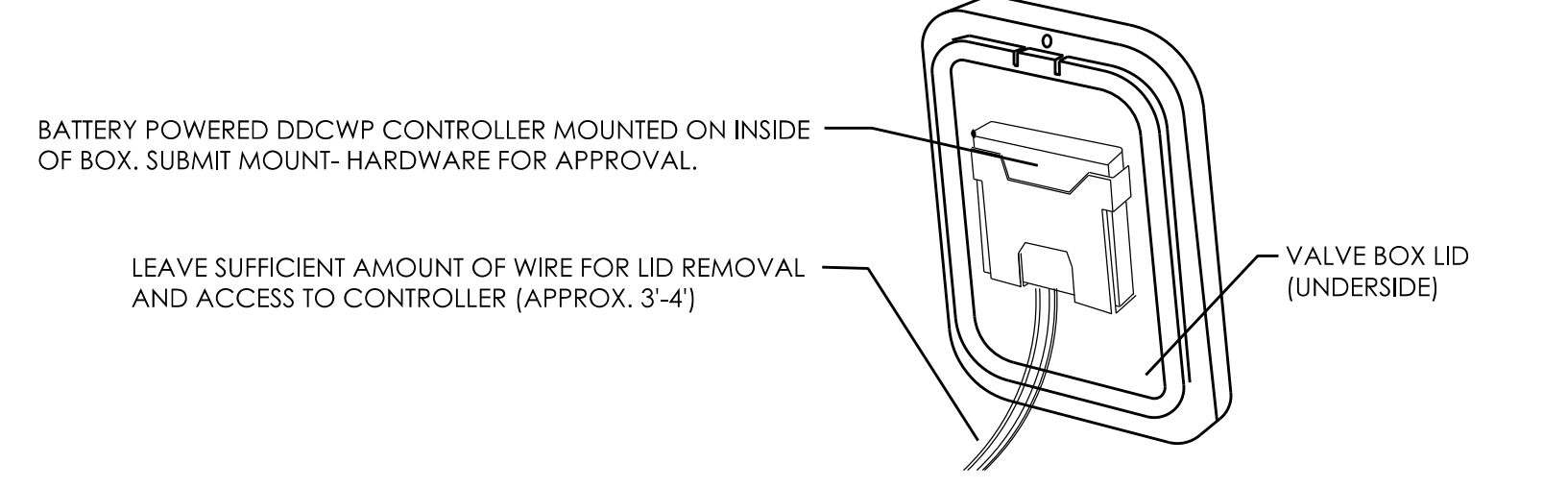

6 BATTERY CONTROLLER (BOX LID MOUNT)  
(NOT TO SCALE)

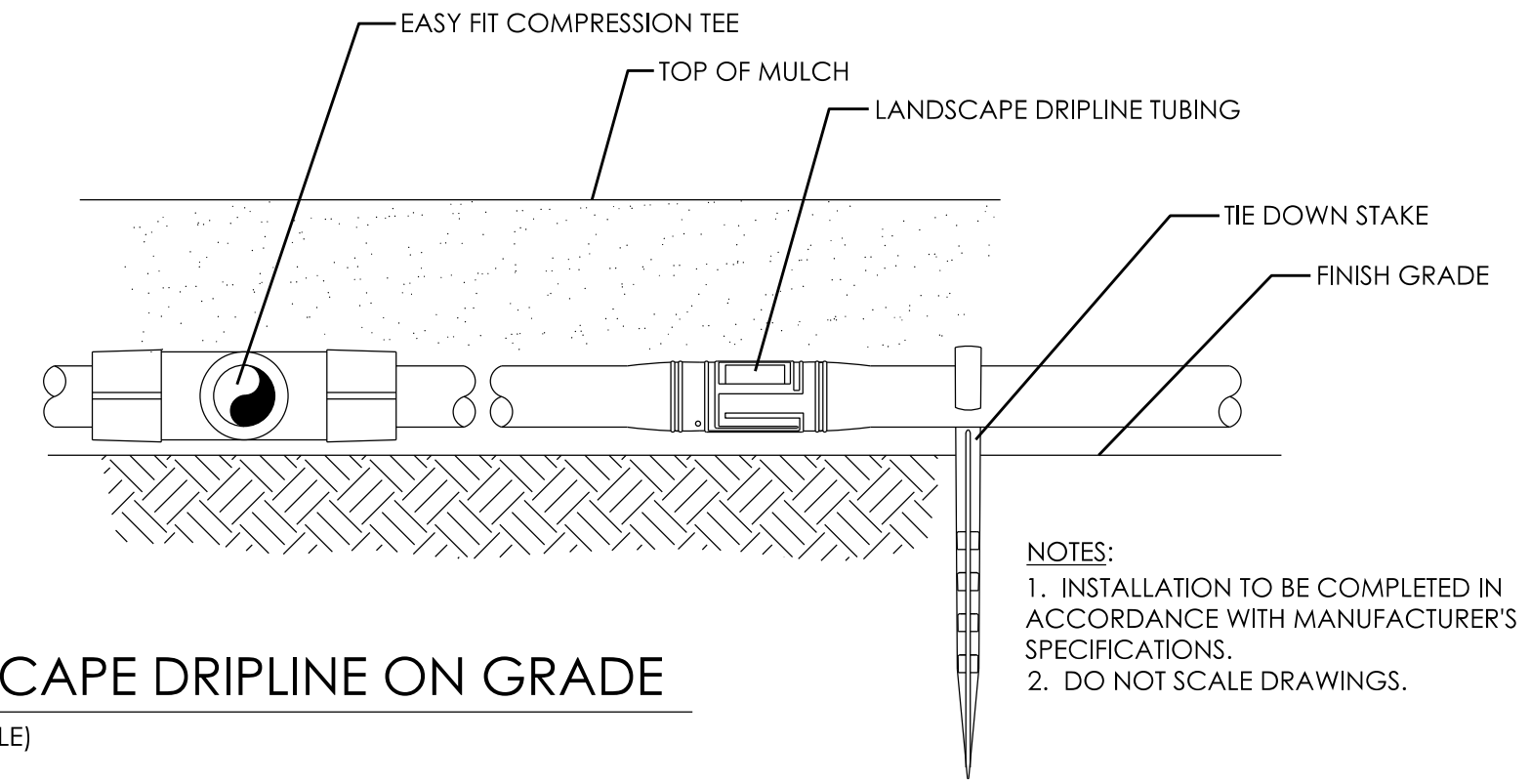

7 LANDSCAPE DRIPLINE ON GRADE  
(NOT TO SCALE)

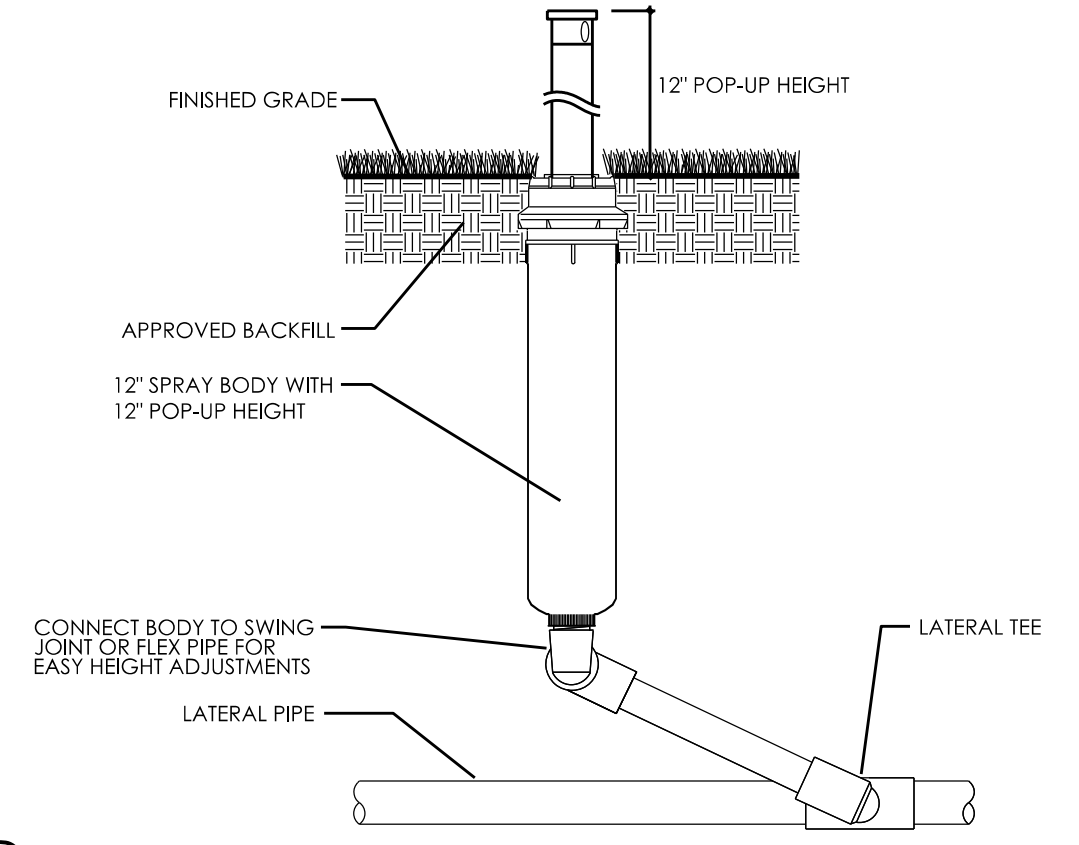

8 12" POP-UP SPRAY HEAD  
(NOT TO SCALE)

1

2

3

4

5

6

D

C

B

A



SHEET I-4

SHEET I-5

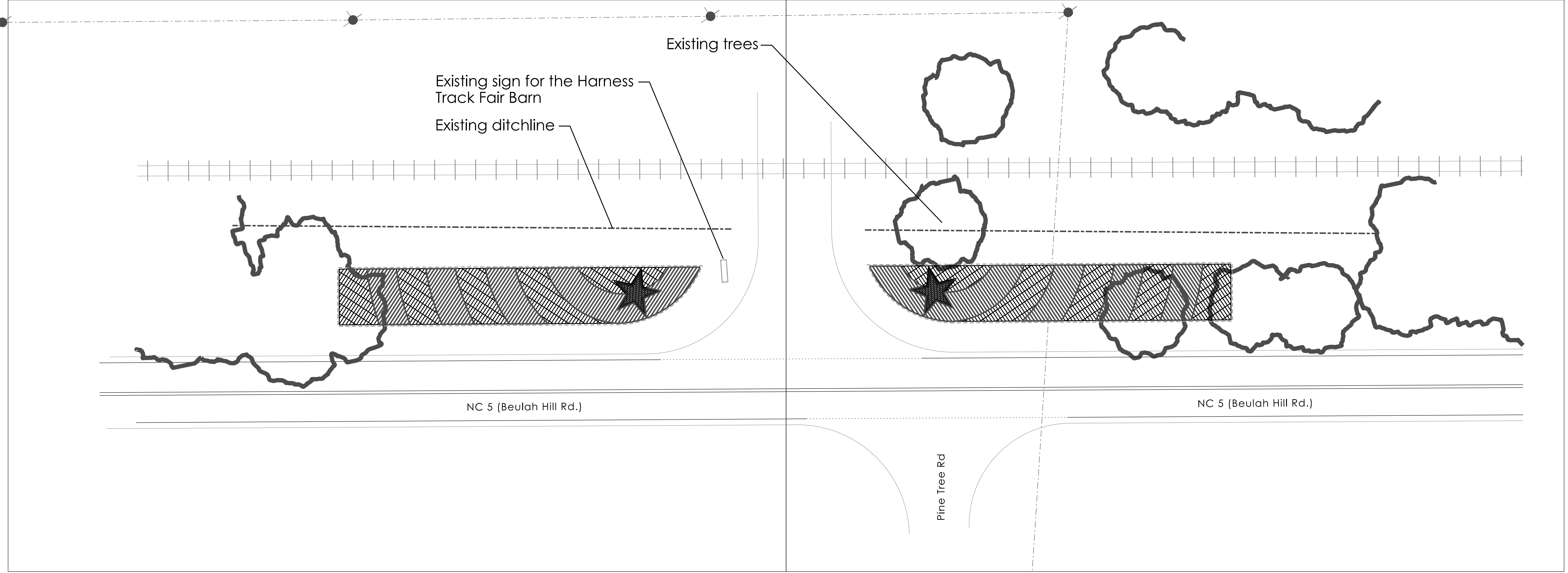

STATE . . . . .  
 W.B.S. # . . . . .  
 T.I.P. # . . . . .  
 FA # . . . . .



AESTHETICS ENGINEERING SECTION  
 NCDOT ROADSIDE ENVIRONMENTAL UNIT  
 1557 MAIL SERVICE CENTER  
 RALEIGH NC 27699 919-733-2920

PLAN : **2024 US Open Annual Plantings Irrigation**  
 PROJECT DESCRIPTION : **NC 5 (Beulah Hill Rd) At Harness Fair Barn**

DESIGNED BY:  
**K. COOPER, P.L.A.**  
 SHEET:  
**IRRIGATION PLAN**  
 DATE  
**11/17/2023**  
 SCALE  
**1" = 20'**  
 SHEET # **I-3** OF **6**

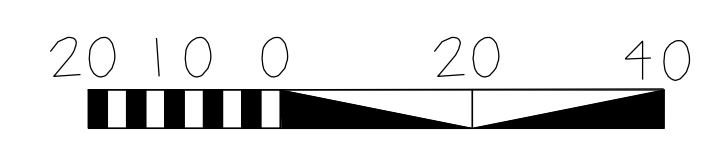



1 2 3 4 5 6

D

C

B

A

Install a new meter, backflow, controller, main line, lateral line, and other irrigation components without damaging any existing plant material and infrastructure. The meter shall be provided by NCDOT Division 8 and tie into the existing water line. Be sure that all components of the irrigation system are placed within the ROW. All pop-up spray heads are to be mounted on 12" risers. A rain sensor is to be installed at the edge of the plant bed.

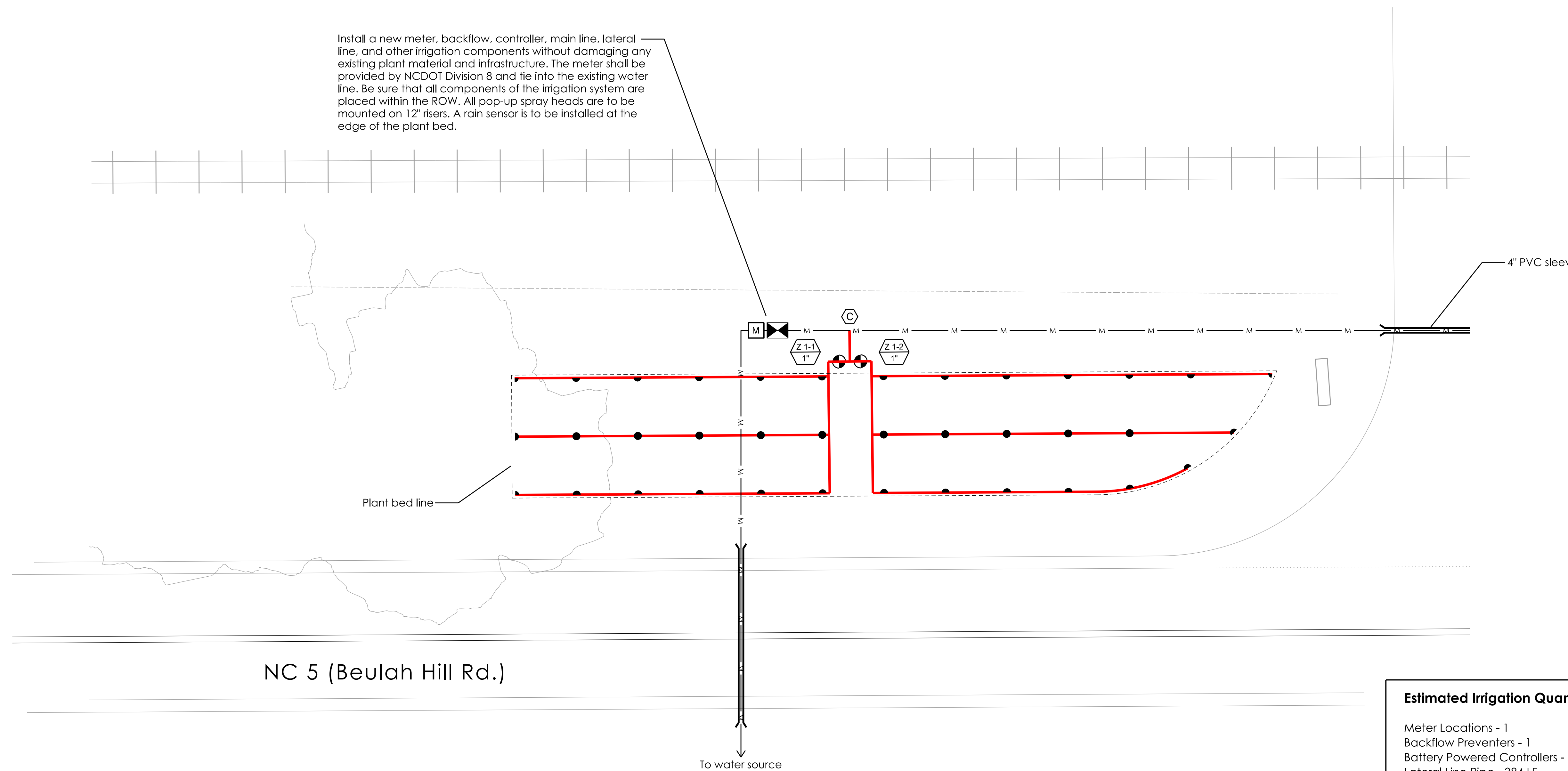

NC 5 (Beulah Hill Rd.)

To water source

Source of water to be determined. See Division Roadside Environmental Engineer for exact location of water tap. Mainline, backflow, and sleeve locations may differ depending on actual location of water source.

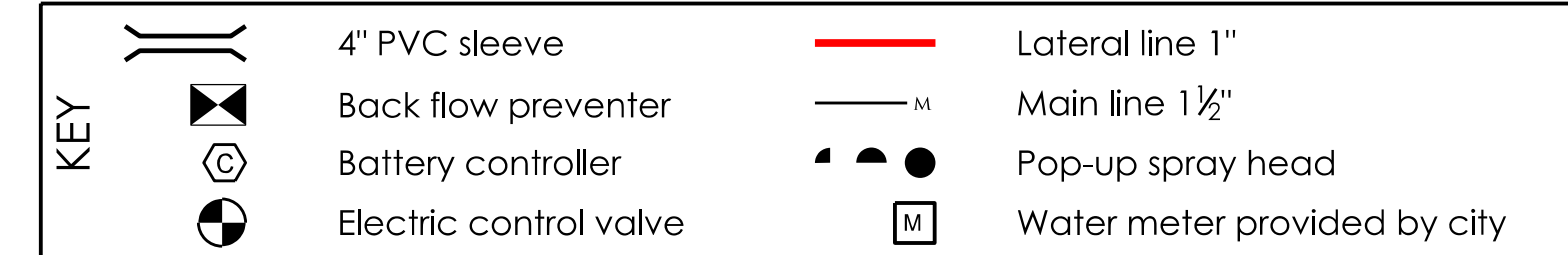
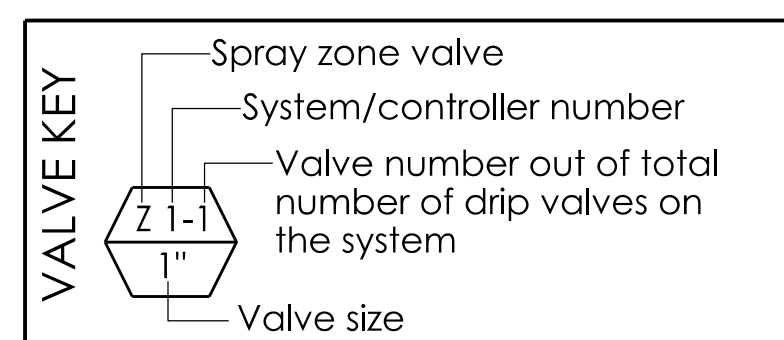

**Estimated Irrigation Quantities**

- Meter Locations - 1
- Backflow Preventers - 1
- Battery Powered Controllers - 1
- Lateral Line Pipe - 384 LF
- Total Main Line Pipe - 277 LF
- Spray Zone Valves - 2
- 10' R Adjustable Pop-up Spray Heads - 37
- Total 4" PVC Sleeve - 60 LF

Quantities are estimated based on design drawings. Refer to plans for any discrepancies. Plans take priority over these estimated quantities. Estimated quantities do not cover all materials necessary for installation. Quantities may be adjusted slightly due to site conditions, specific irrigation equipment, and implementation, or as directed by the NCDOT Engineer.

STATE . . . . .  
W.B.S. # . . . . .  
T.I.P. # . . . . .  
FA # . . . . .



AESTHETICS ENGINEERING SECTION  
NCDOT ROADSIDE ENVIRONMENTAL UNIT  
1557 MAIL SERVICE CENTER  
RALEIGH NC 27699 919-733-2920

PLAN : **2024 US Open Annual Plantings Irrigation**  
PROJECT DESCRIPTION : **NC 5 (Beulah Hill Rd) At Harness Fair Barn**

DESIGNED BY : **K. COOPER, PLA**

SHEET :

IRRIGATION PLAN

DATE

11/17/2023

SCALE

1" = 10'

SHEET # OF

**I-4 6**

1 2 3 4 5 6

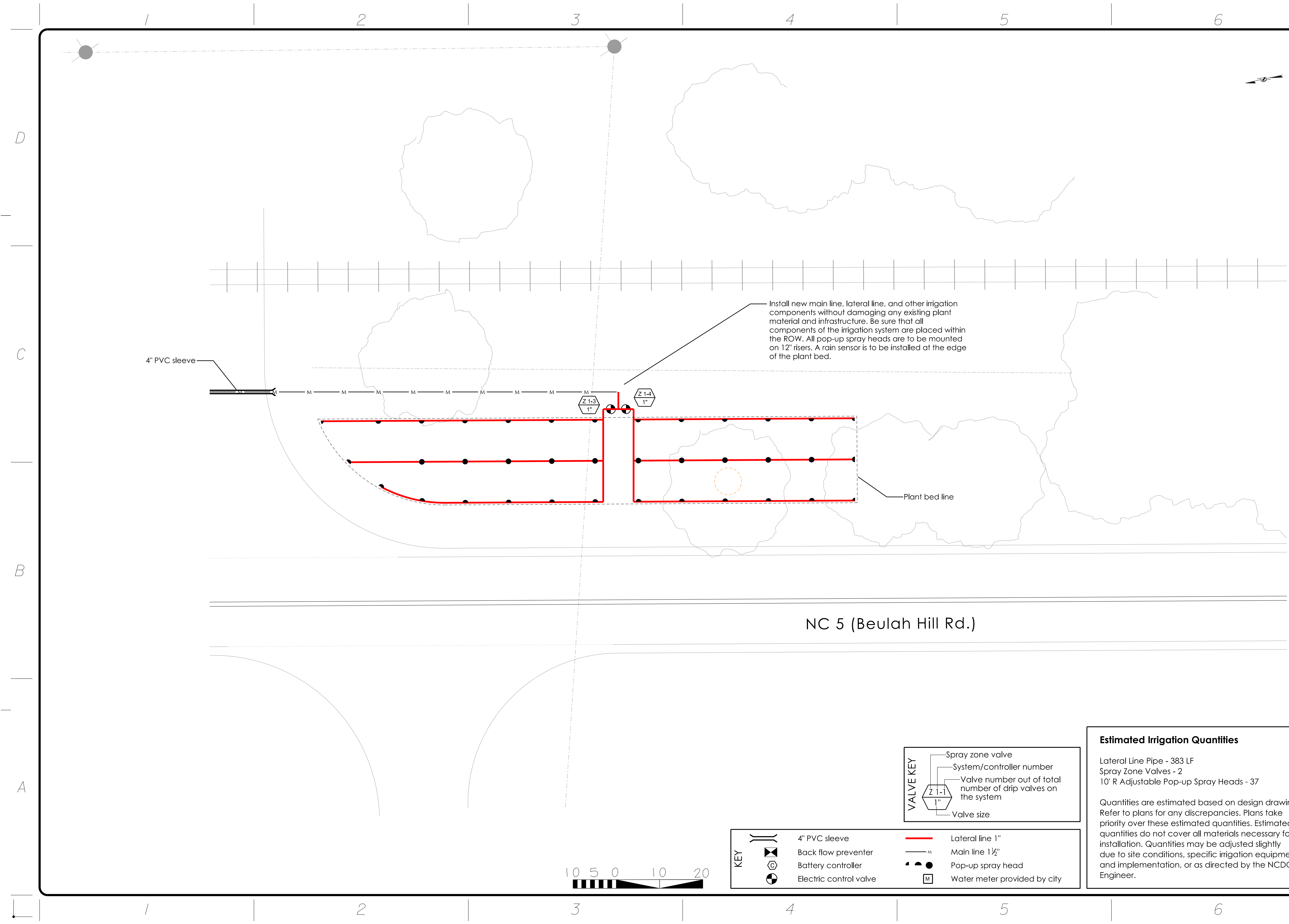

4" PVC sleeve

Install new main line, lateral line, and other irrigation components without damaging any existing plant material and infrastructure. Be sure that all components of the irrigation system are placed within the ROW. All pop-up spray heads are to be mounted on 12" risers. A rain sensor is to be installed at the edge of the plant bed.

Plant bed line

NC 5 (Beulah Hill Rd.)

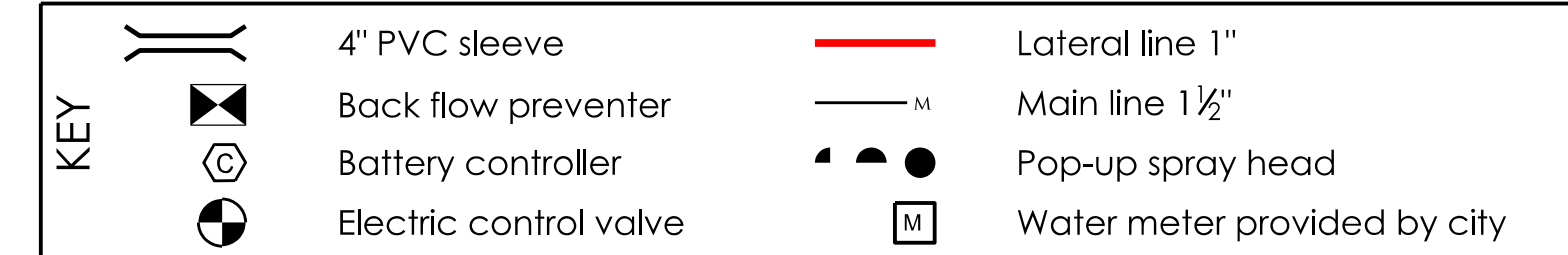
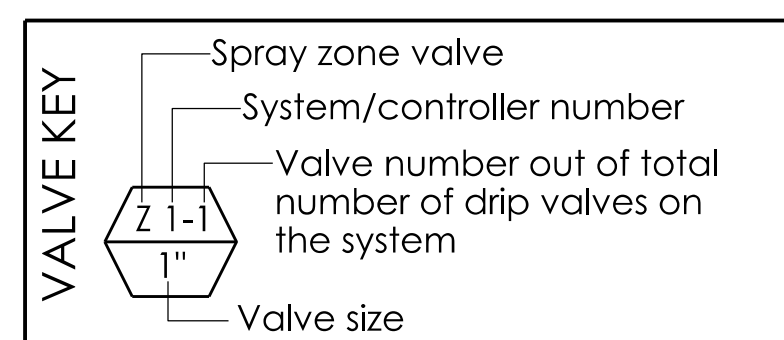

**Estimated Irrigation Quantities**

Lateral Line Pipe - 383 LF  
 Spray Zone Valves - 2  
 10" R Adjustable Pop-up Spray Heads - 37

Quantities are estimated based on design drawings. Refer to plans for any discrepancies. Plans take priority over these estimated quantities. Estimated quantities do not cover all materials necessary for installation. Quantities may be adjusted slightly due to site conditions, specific irrigation equipment, and implementation, or as directed by the NCDOT Engineer.

STATE . . . . .  
 W.B.S. # . . . . .  
 T.I.P. # . . . . .  
 FA # . . . . .

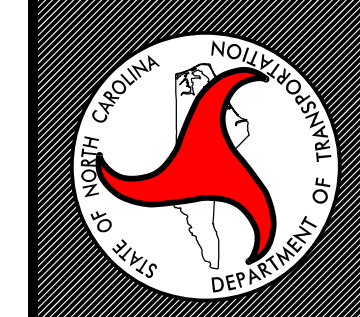

AESTHETICS ENGINEERING SECTION  
 NCDOT ROADSIDE ENVIRONMENTAL UNIT  
 1557 MAIL SERVICE CENTER  
 RALEIGH NC 27699

PLAN : **2024 US Open Annual Plantings Irrigation**  
 PROJECT DESCRIPTION : **NC 5 (Beulah Hill Rd) At Harness Fair Barn**

DESIGNED BY : **K. COOPER, PLA**  
 SHEET : **IRRIGATION PLAN**  
 DATE : **11/17/2023**  
 SCALE : **1"=10'**  
 SHEET # **I-5** OF **6**

Install a new meter, backflow, control panel, main line, lateral line, and other irrigation components without damaging any existing plant material and infrastructure. The meter shall be provided by NCDOT Division 8 and tie into the existing municipal water line. Be sure that all components of the irrigation system are placed within the ROW. All pop-up spray heads are to be mounted on 12" risers. A rain sensor is to be installed at the edge of the plant bed.

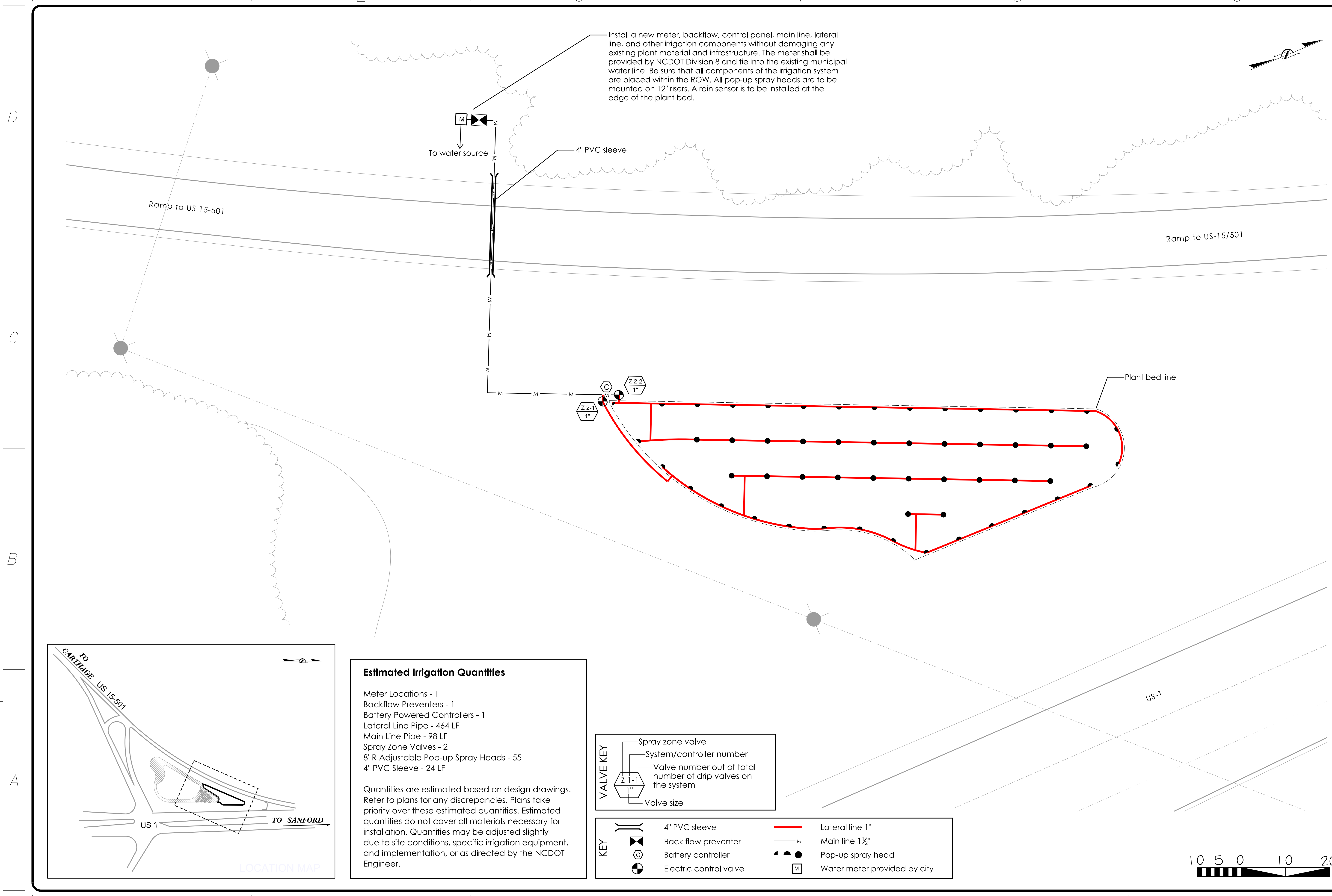

Ramp to US 15-501

Ramp to US-15/501

Plant bed line

To water source  
 4" PVC sleeve

**Estimated Irrigation Quantities**

Meter Locations - 1  
 Backflow Preventers - 1  
 Battery Powered Controllers - 1  
 Lateral Line Pipe - 464 LF  
 Main Line Pipe - 98 LF  
 Spray Zone Valves - 2  
 8' R Adjustable Pop-up Spray Heads - 55  
 4" PVC Sleeve - 24 LF

Quantities are estimated based on design drawings. Refer to plans for any discrepancies. Plans take priority over these estimated quantities. Estimated quantities do not cover all materials necessary for installation. Quantities may be adjusted slightly due to site conditions, specific irrigation equipment, and implementation, or as directed by the NCDOT Engineer.

